

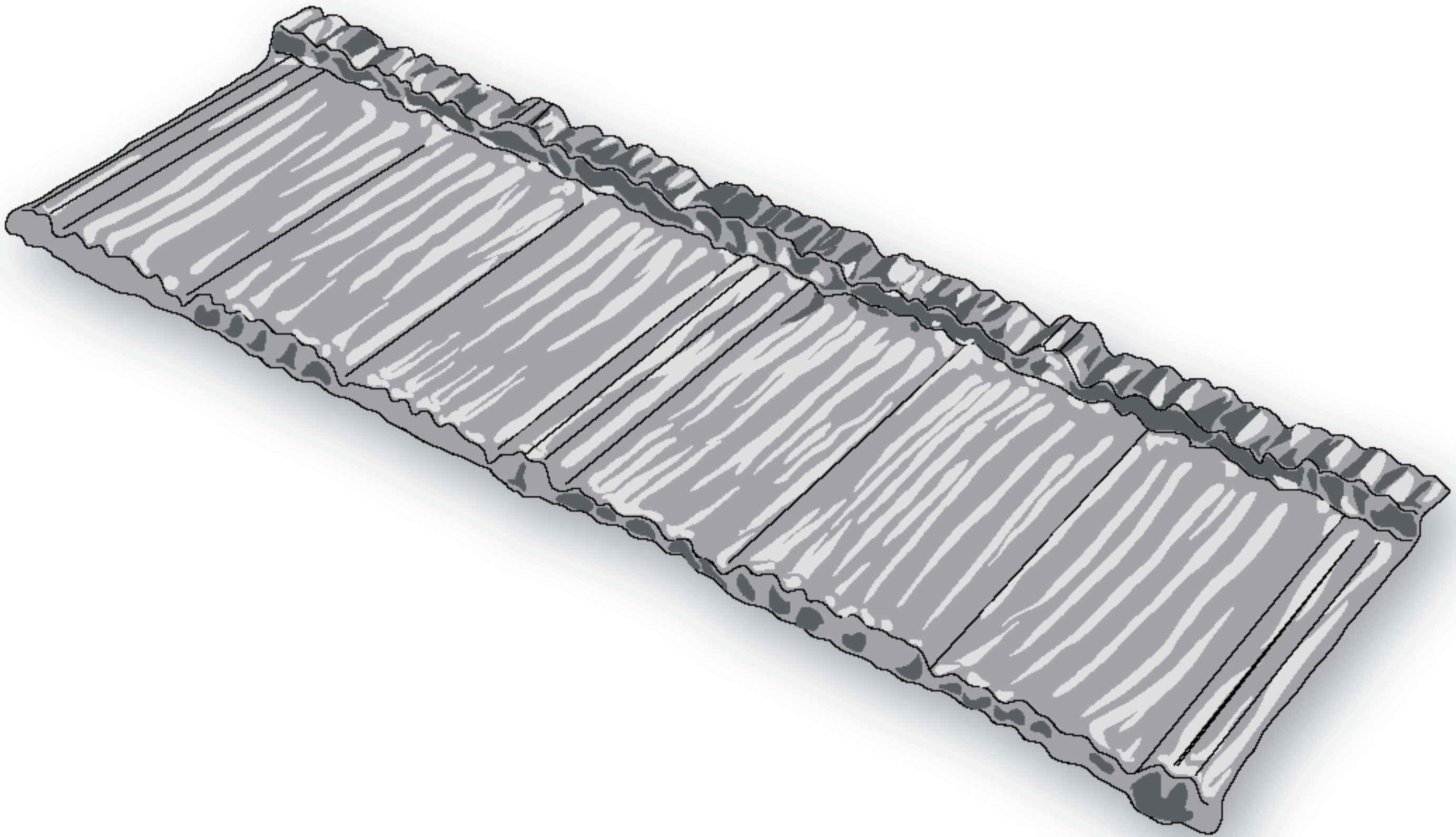

MetroSHAKE™

Batten-less Installation Details



Issued December 29, 2005 | Revised February 22nd 2009

INSTALLATION WARNING!

These installation details are provided to demonstrate a recommended installation method for Metro roof panels and accessories. The details and information in this document reflect current roofing practices used in the United States. Installers of Metro roof panels & accessories should, have knowledge of roof structures, an understanding of how to work with stone-coated steel panels and accessories and be experienced at working on sloped roof environments.

Metro recommends installers of its products use a Metro Installation Kit (1-Cutter, 1-Foot Bender & 1-Foot Bender Attachment) and to have completed a 'SMART-Start On-Site Installer Training Orientation Program' (<http://metro.roofs.com/SmartStartTraining.cfm>) for each profile they attempt to install. Metro does not consider its products to be a 'Do-It-Yourself' (D.I.Y) product, mainly due to the need for specialized cutting & bending tools used during installation.



INTRODUCTION

Installation Tools:

- Metro Installation Kit
 - 1-Cutter, 1-Foot Bender
 - 1-Full Panel Bender attachment
 - 2-Batten Spacers
- Metro SMART-Hand Tool Kit
 - 12-V Impact Driver
 - Red & Green Snips
 - 3" Hand Seamers
 - Safety Gloves & Safety Glasses

Other Tools:

- Nail Gun
- Hammer
- Tape Measure
- Caulking Gun
- Sting-Line

General:

These installation details are designed to be used in conjunction with Metro's SMART-Start On-Site Installer Training Program. A certificate of completion is awarded to those installers who are considered to have satisfactorily completed the Metro SMART-Start On-Site Training Program for each Metro profile.

Metro Batten-Less install methods ensure the simplest application. Starting with perimeter metal flashings & valleys, then followed by field panels installed from the Fascia to the Ridge. The next step is to measure, cut & bend panels to fit the areas around the perimeter of the field panels at Rakes, Ridges, Hips & Valleys. The final step is to install the Trim Caps and a final quality control check of the job.



In cold climate zones with Cathedral Ceilings a Counter-Batten and Batten grid system is suggested to help prevent ice-damming.

SMART-Steps to a perfect install:

1. Perimeter Flashing & Valley Metal
2. Full-Field Panels
3. Rake cut sections
4. Hip & Valley cut & sections
5. Ridge cut & bent sections
6. Pipe, Chimney / Skylight flashing
7. Trim Caps
8. Overall quality control job check

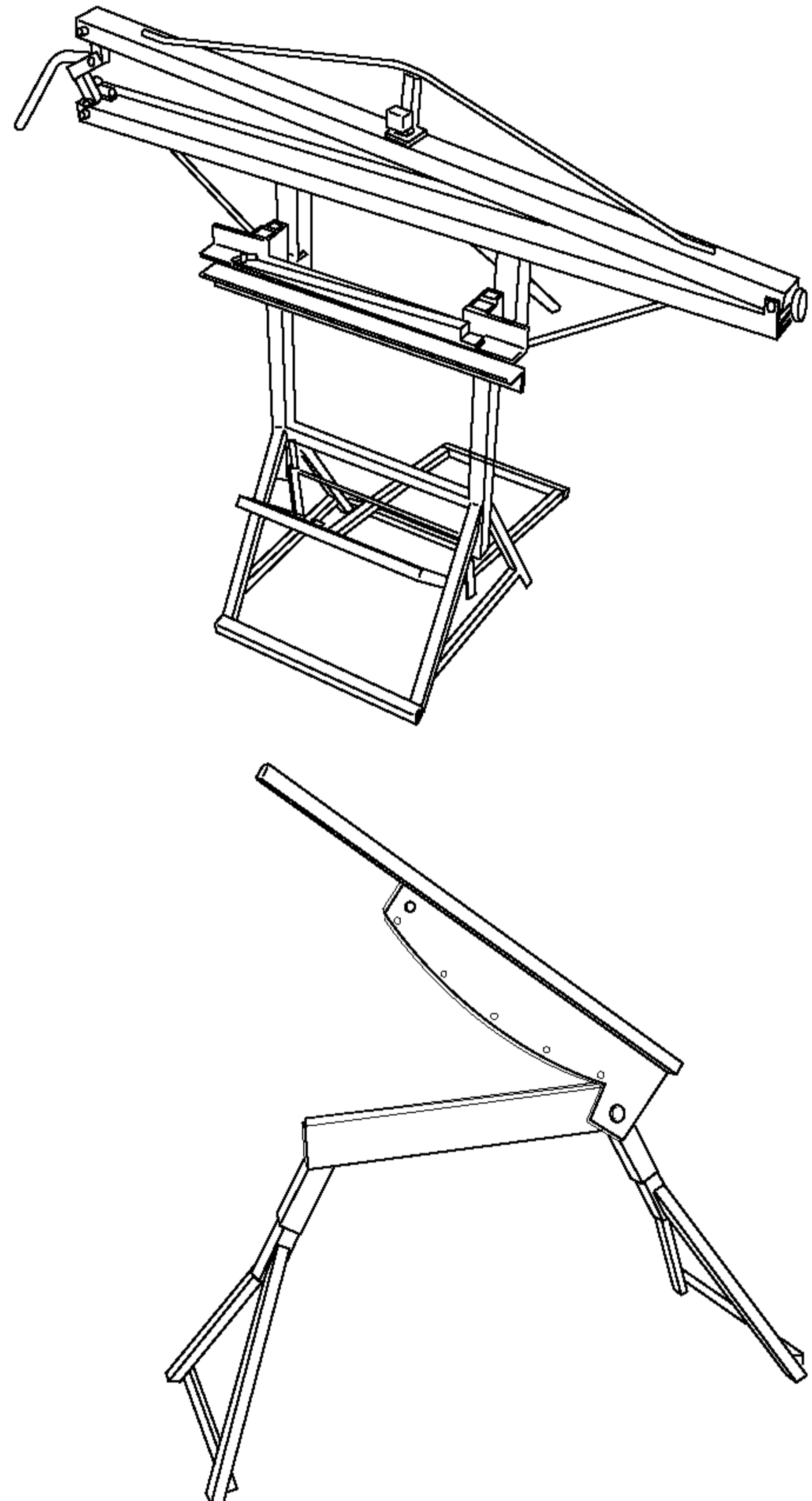



MetroSHAKE™

Batten-less Installation Details

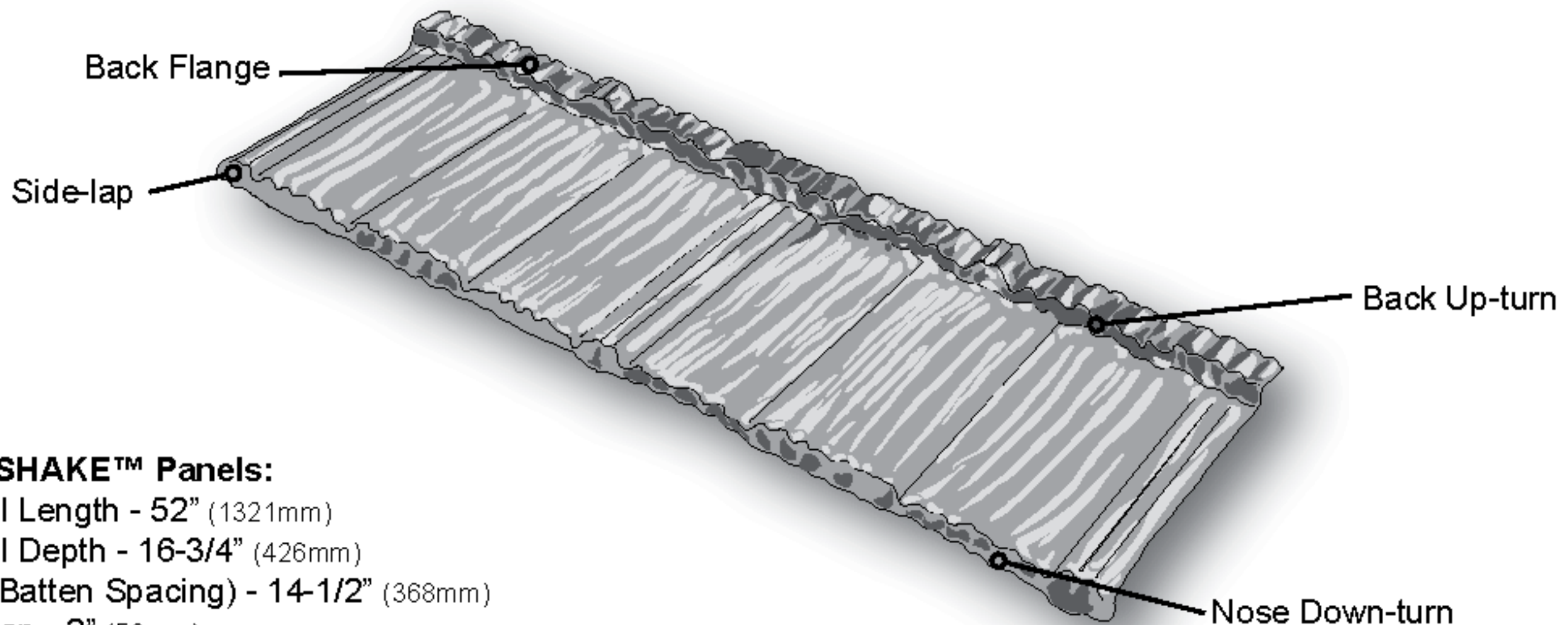

MetroSHAKE™ Panels:

Overall Length - 52" (1321mm)
Overall Depth - 16-3/4" (426mm)
Pitch (Batten Spacing) - 14-1/2" (368mm)
Side-Lap - 2" (50mm)
Back Flange - 1" (25mm)
Back Up-Turn - 1" (25mm)
Panel Cover - 49-1/2" (1258mm)
Panels Per Pallet - 400-pcs
Panels Per Square (100 sq/ft)- 20-pcs (0.465 panels per Sq. M)

Materials:

Metro panels are produced from Aluminum-zinc alloy coated steel complying with ASTM A792.

Packing and Storage:

A pallet of Metro panels contains approximately 20 squares. Care should be taken to store panels under a weather-proof cover or inside in an area free from moisture.

Roofing felt

Unless local conditions require otherwise, either one layer of type 30, or two layers of Type 15 lb. roofing felt or equal should be used with Metro panels.

Sealant/Caulking

Only exterior grade urethane or (non-acidic) caulking should be used for sealant.

Fasteners:

All fasteners (Nails or Screws) used on a Metro roof for panels, trim caps and accessory items shall meet or exceed the corrosion resistant standard as defined in ASTM B-117, (1,000-hr minimum Salt Spray Corrosion Resistance).

For HVHZ (High Velocity Hurricane Zone) areas refer to local code requirements and /or Metro website (www.metroroofs.com) for details.

Testing:

Metro panels have been tested in accordance with local, national & international building codes. Testing has been conducted to evaluate fire, wind, penetration, water infiltration, and durability resistance. Information regarding specific tests and approvals can be obtained from Metro Roof Products.

Ventilation:

Ensure proper attic ventilation as prescribed per local codes. Either Smart Vents or Ridge venting can be installed to achieve adequate ventilation.

Warranty:

Metro panels carry a limited warranty for fifty years. This limited warranty is transferable and does not cover damage due to improper handling or installation.

Dissimilar Metals:



To avoid adverse corrosion effects caused by dissimilar metals, COPPER and LEAD flashings should not be used with Metro roof products and accessories. (refer to Metro SMARTbrief #02004)

Finish coating

Minor scuffing of Metro panels can be repaired with a Touch-Up kit from Metro Roof Products. Use the Touch-Up kit Metro basecoat (*not caulking*). Unfinished flashing materials can be painted with durable acrylic aerosol paints. Colored aerosol paints should never be sprayed on panels or accessories made by Metro Roof Products.



STONE-COATED ACCESSORIES

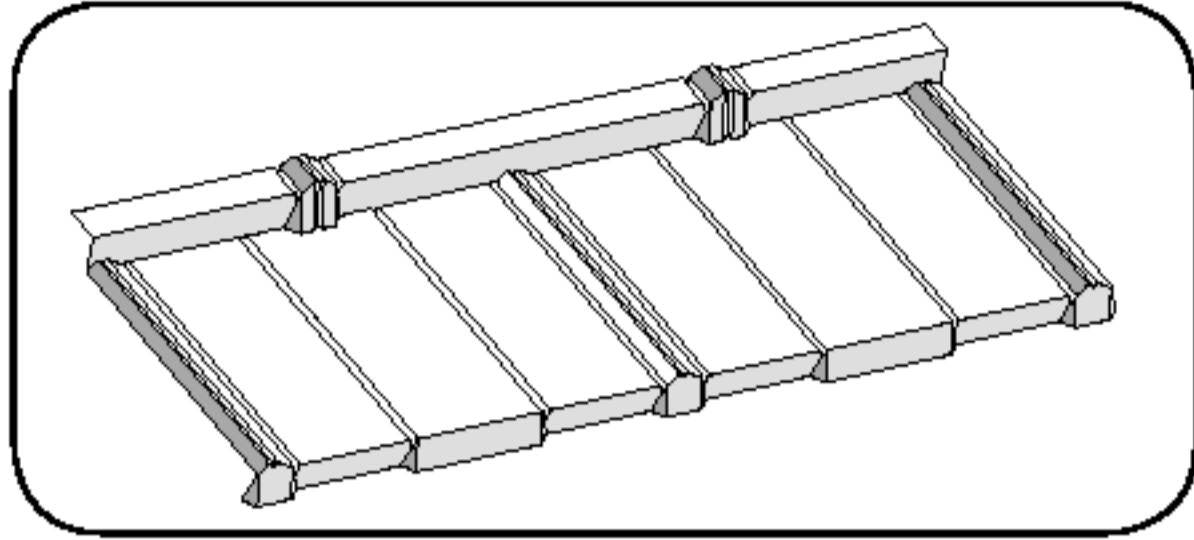

MetroSHAKE™
52" x 16.5" - 5.5 lbs.

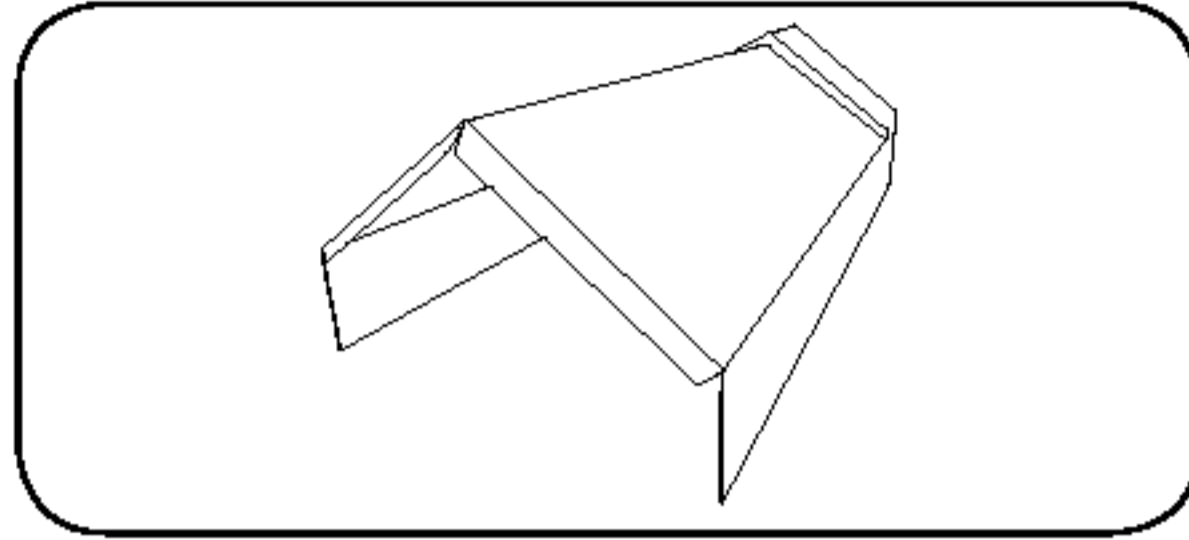

'V' Trim
14.5" x 6" - 1 lbs.

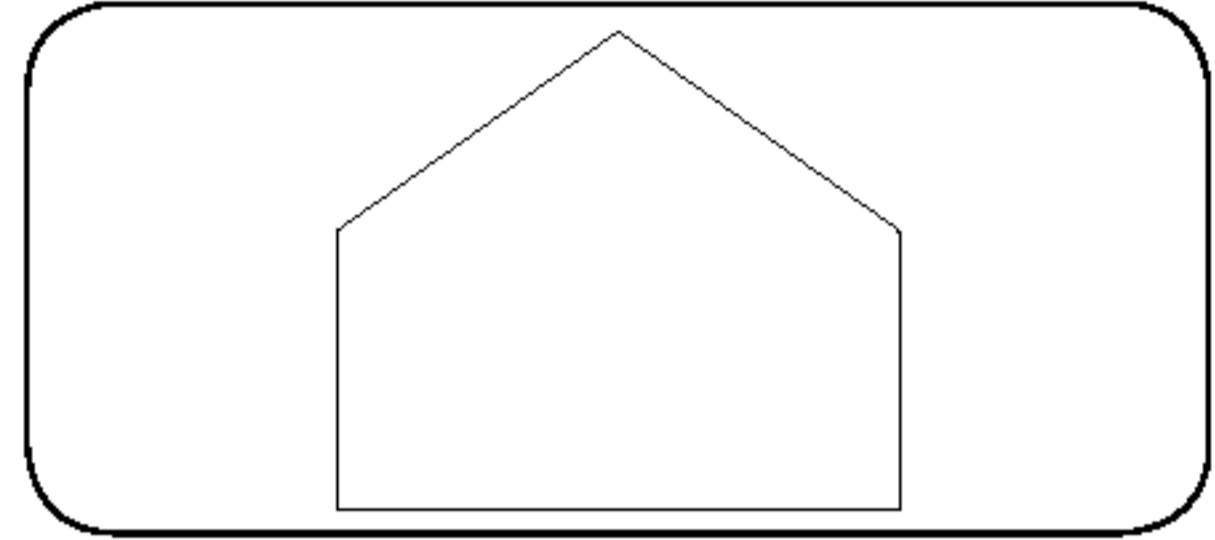

Trim End Disc
6" x 4" - .15 lbs.

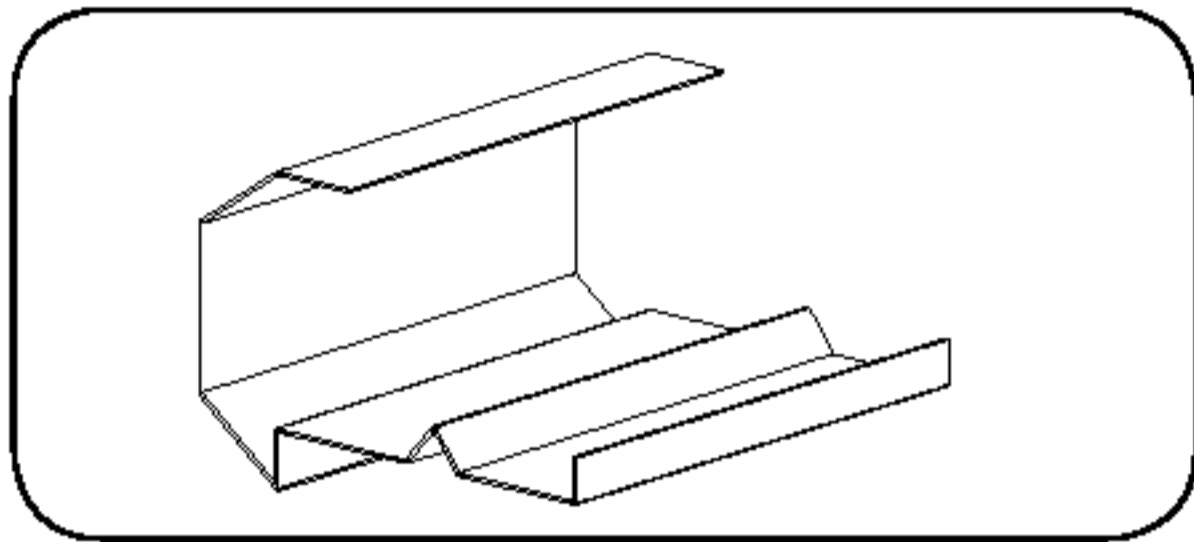

Rake Channel Shake
79" X 2" X 1" - 3.0lbs.

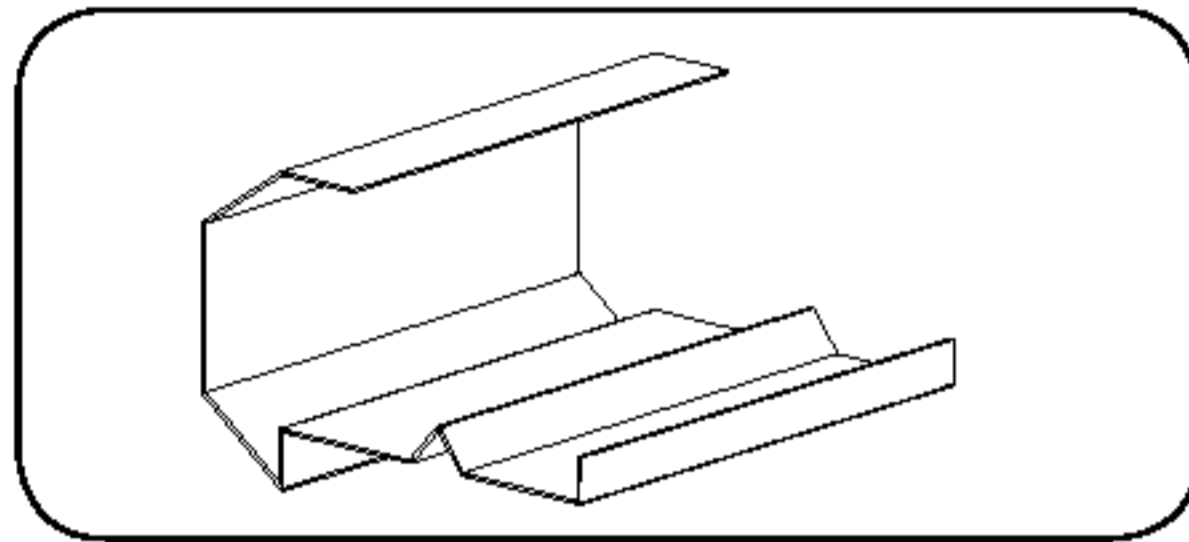

Rake Channel Shake-I
79" X 2" X 1-1/2" - 3.0lbs.

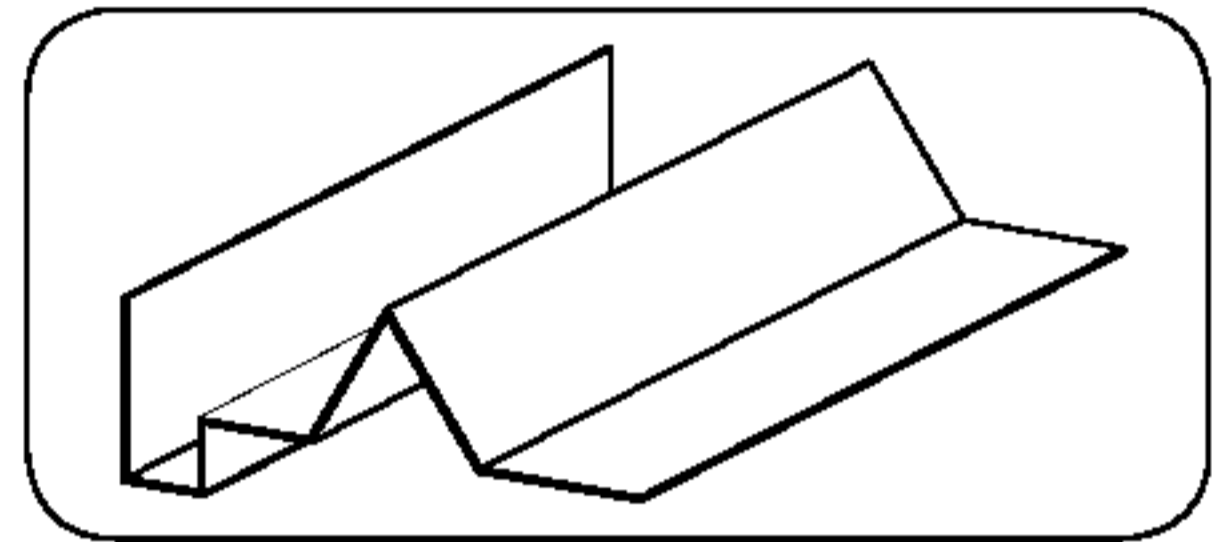

Shake-Tile 'V'-Bat Riser
79" X 2-3/4" - 3.75 lbs.

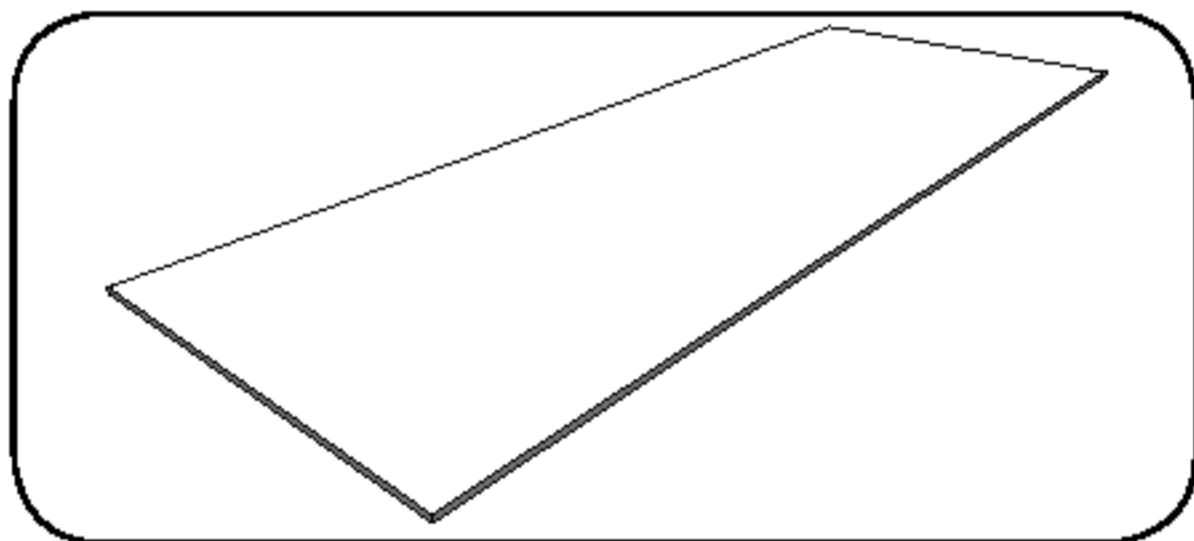

Flat-Stock
79" x 2.5" - 3.5 lbs.

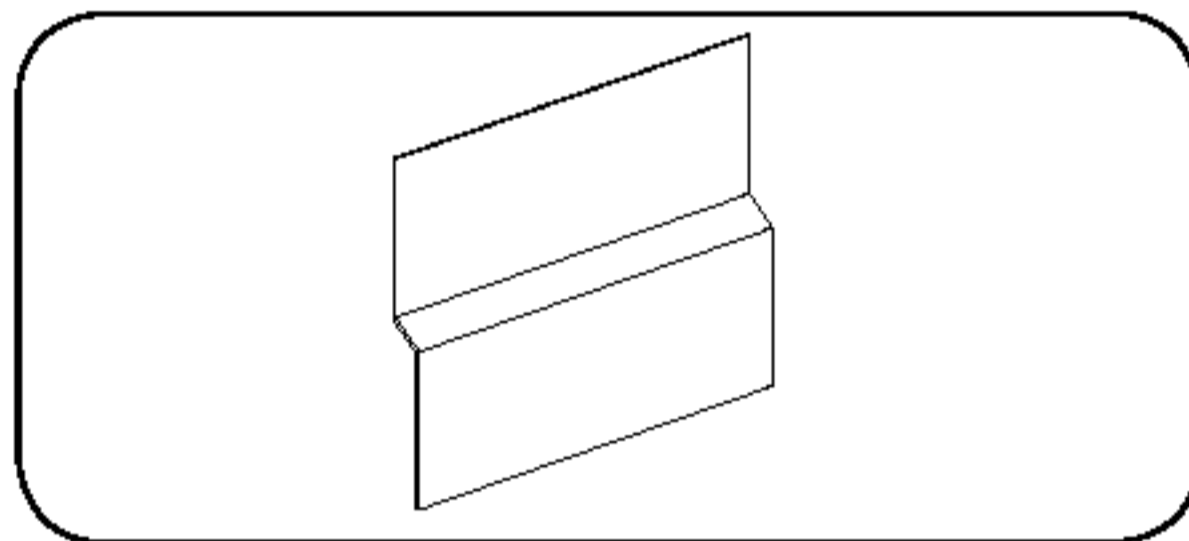

1-3/8" Z-Bar
79" X 2" X 3-1/4" - 3.3lbs.

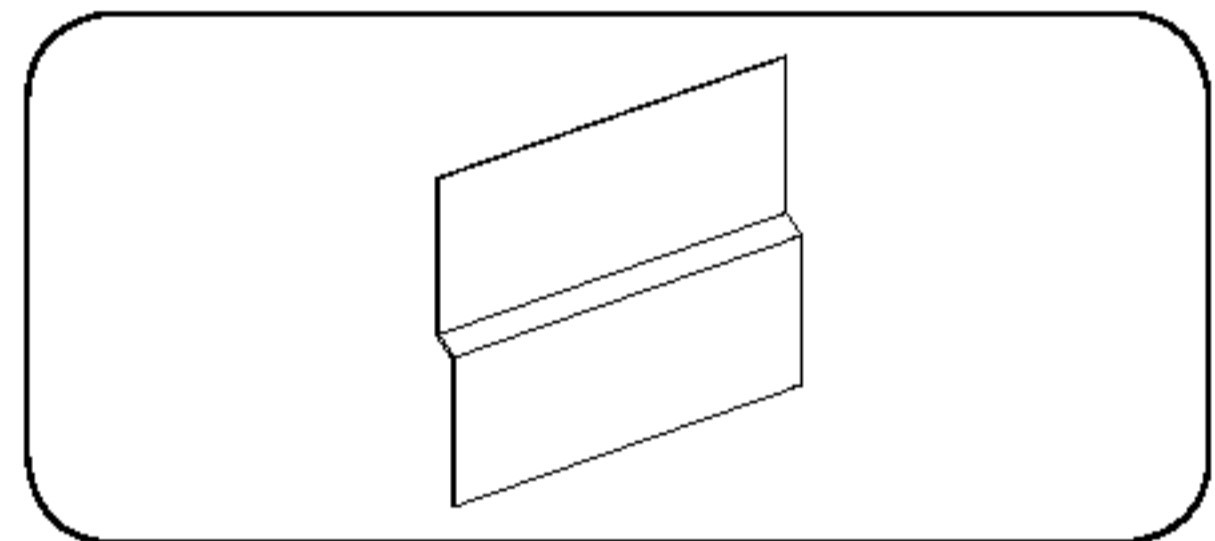

2.5" Z-Bar
79" X 2-1/2" - 3.5lbs.

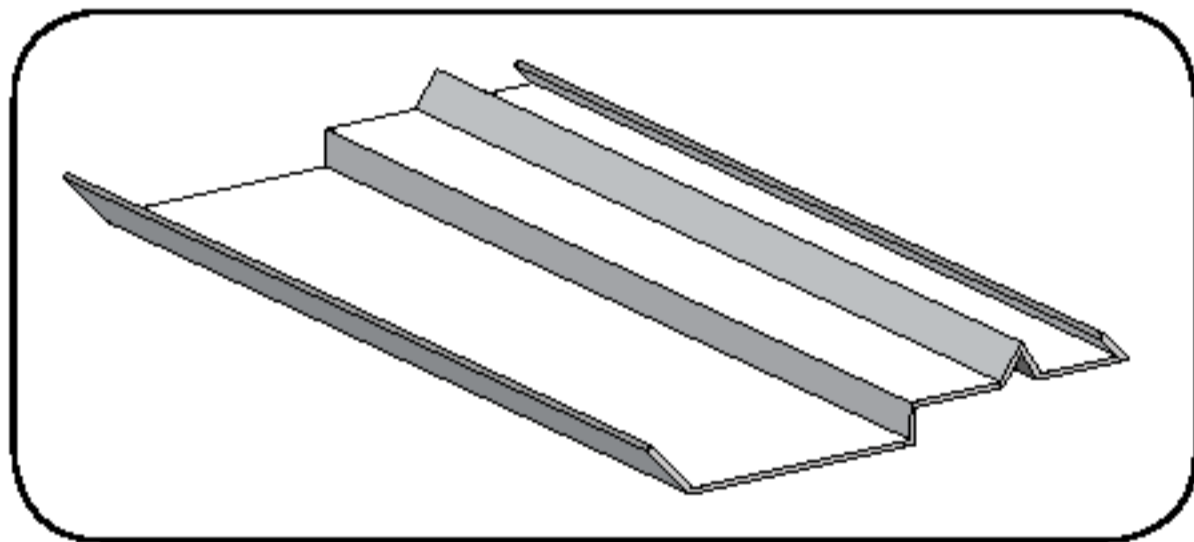

Tie-In Metal
79" X 4" - 4.0lbs.

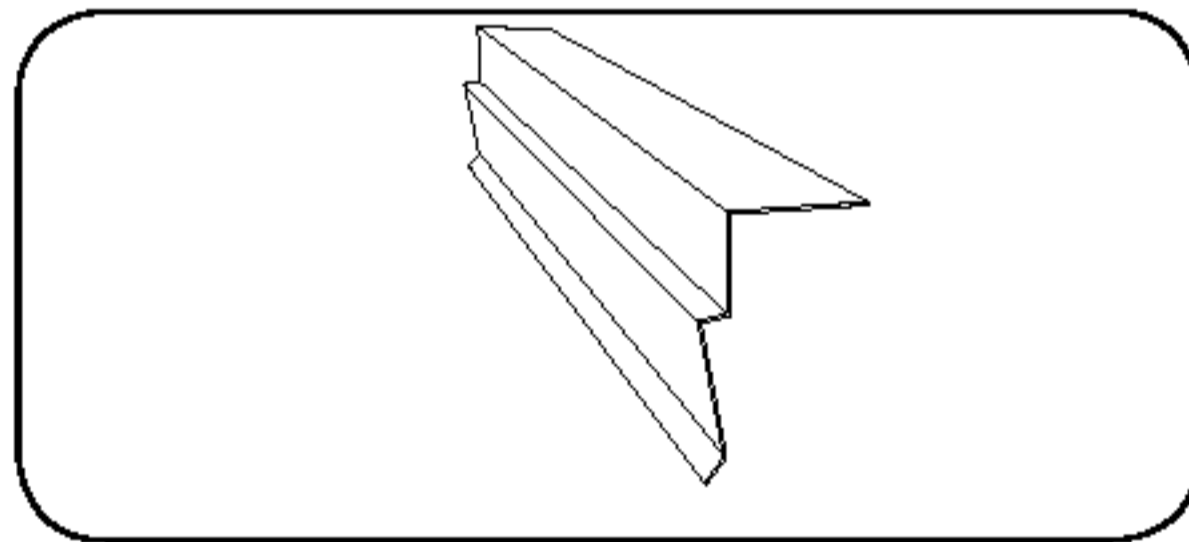

Tile Rake Metal
79" X 2" X 2" X 1-3/4" - 3.5lbs.

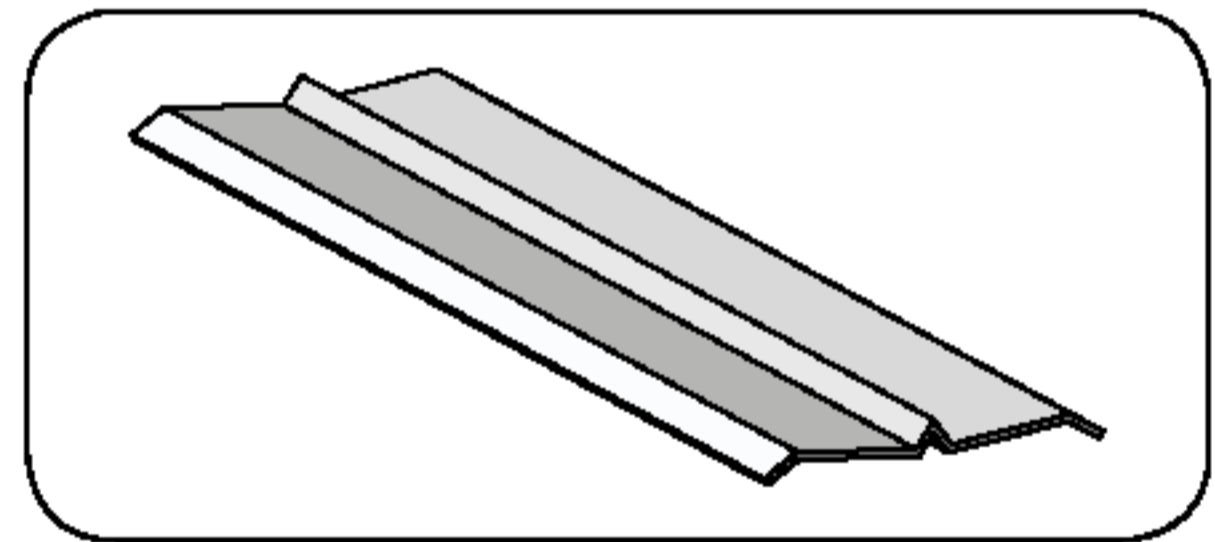

Valley Center Cover
79" X 5" - 3.5lbs

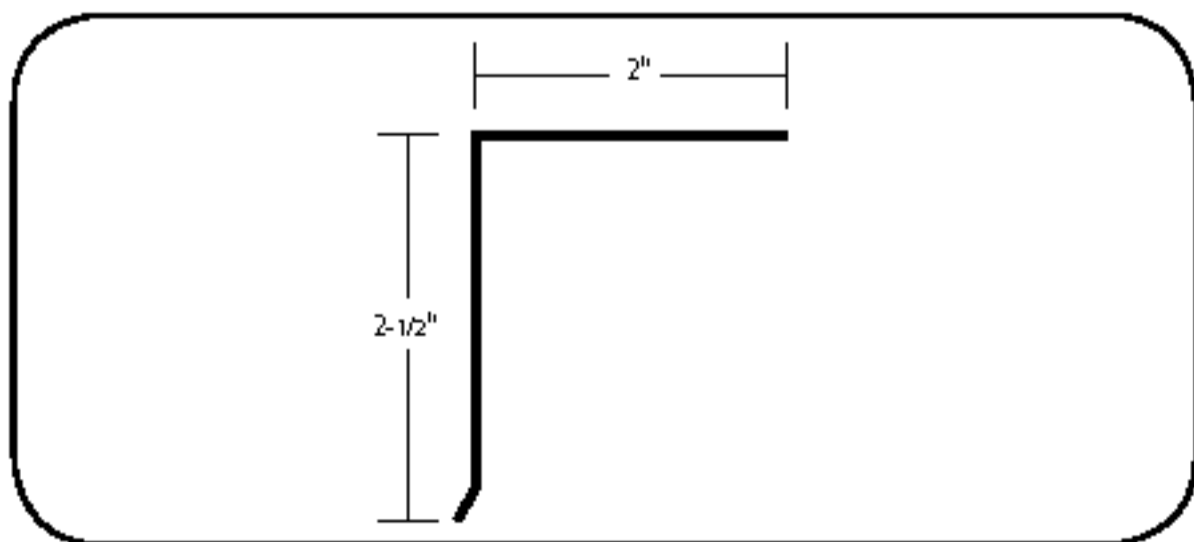

FL Drip Edge
79" X 2" X 3-1/4" 3.3lbs.

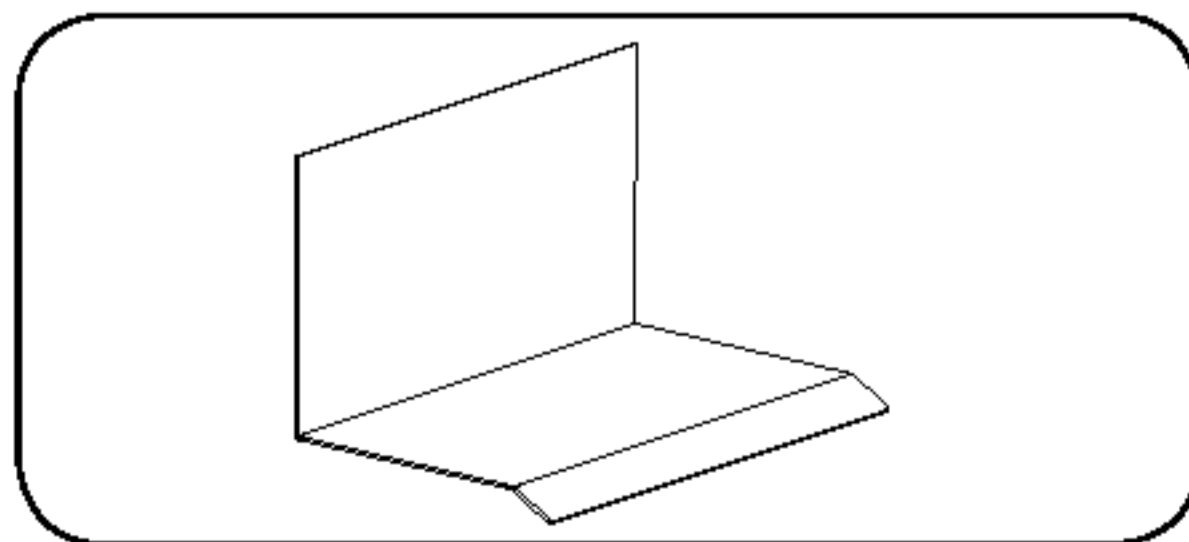

2.5" Head-wall
79" x 2.5" - 3.3 lbs.

METRO SMART ACCESSORIES - STONE COATED

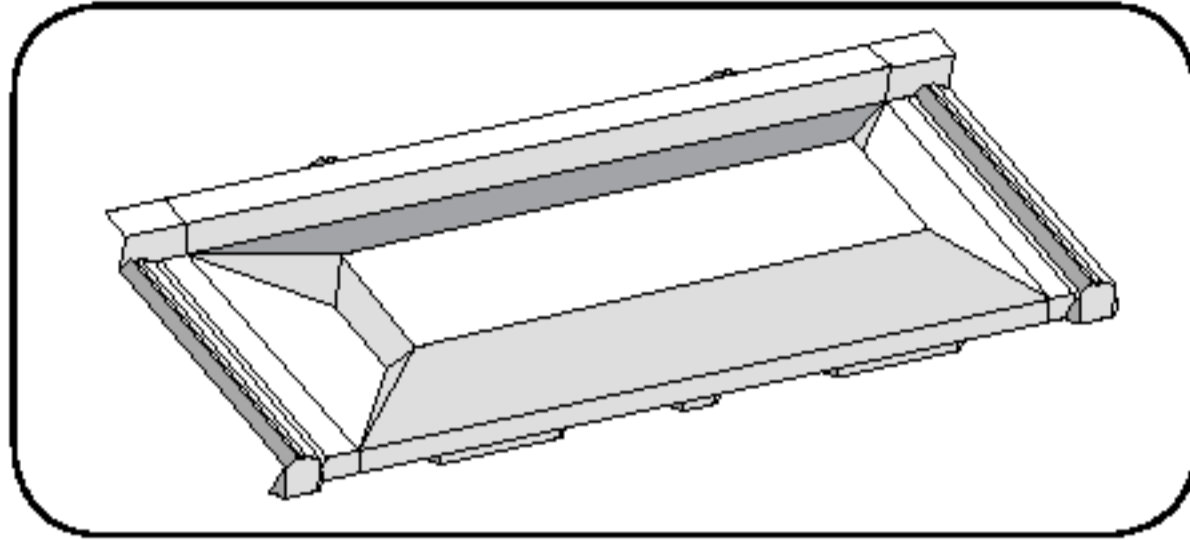

MetroShake SMARTvent
52" x 14.5" x 3.5" - 10.5 lbs.
Net Free Vent Area 82.5"

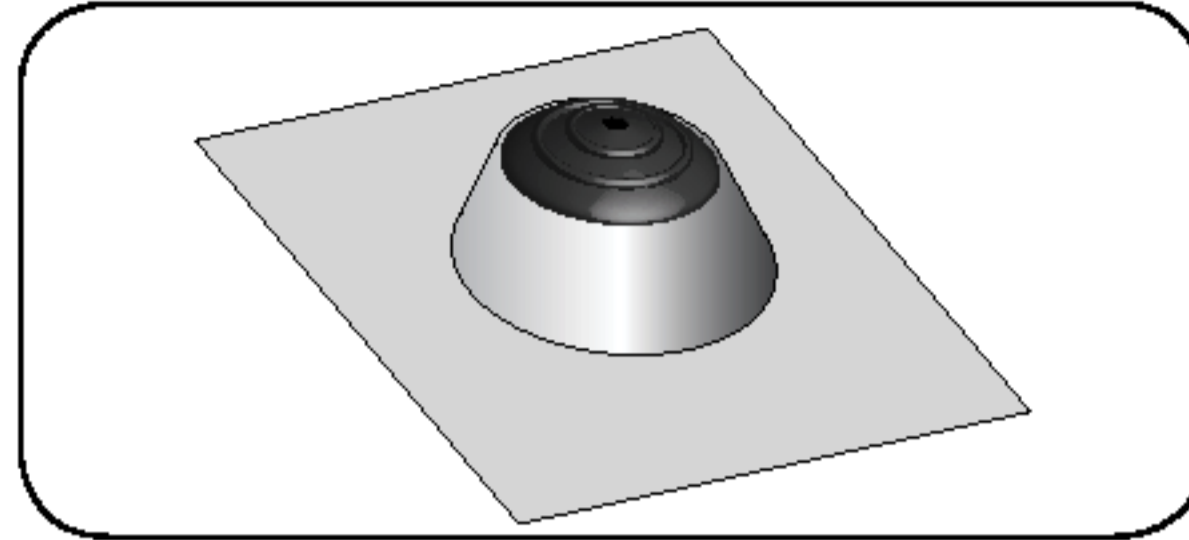

SMART-jack
18" x 18" x 4.5" - 1lbs.
Fits 1" - 3" Dia., pipes.

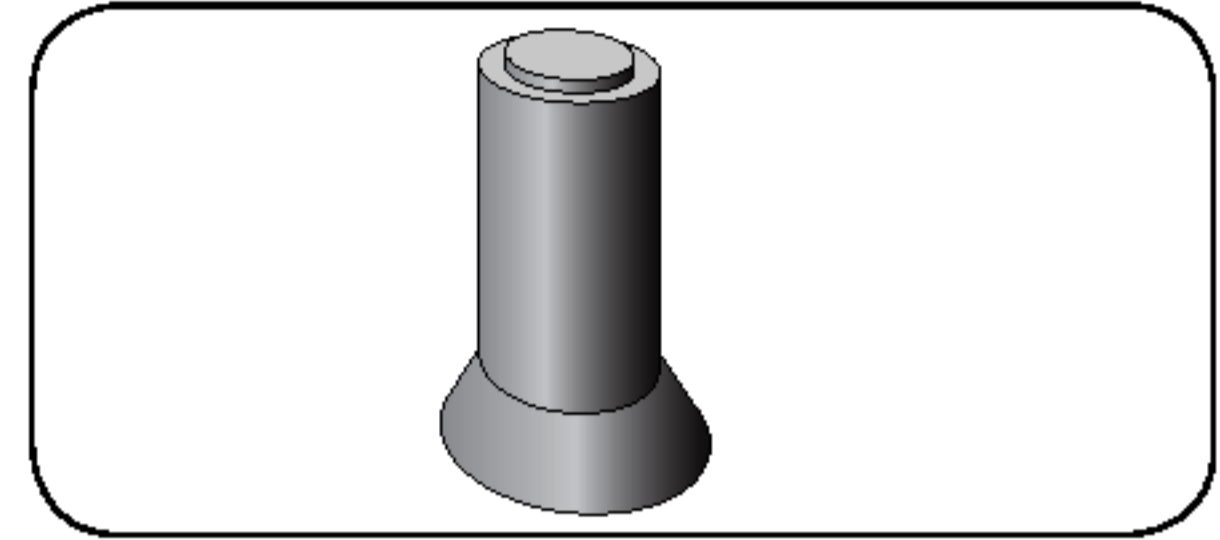

SMART-Sleeve Universal Pipe Cover
Fits pipes 3/4" to 4" in Dia., Available as a single unit or in 6-Pack boxes.

PAINTED ACCESSORIES

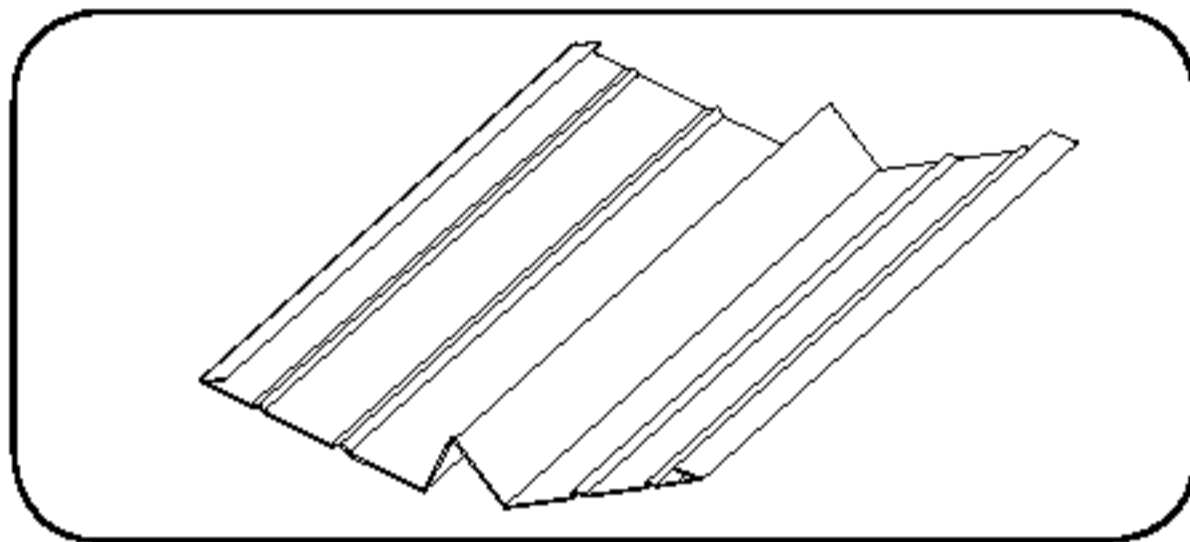

20" Double 'V' Valley Metal
120" x 20" x 2"
12.5 lbs.

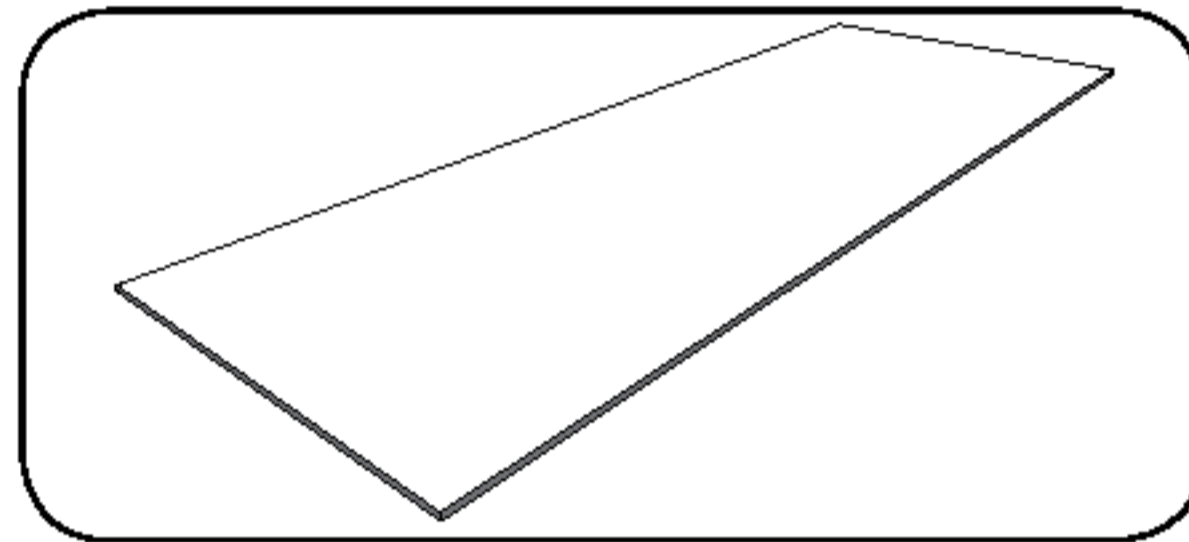

Flat-Stock
52" x 18" - 5.5 lbs.

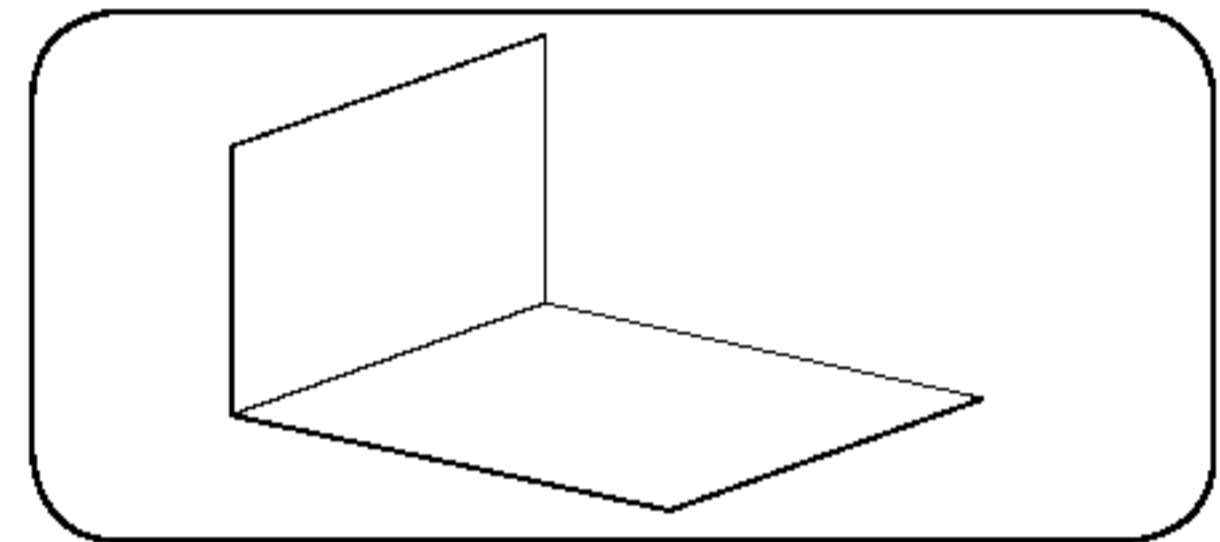

Chimney Saddle
60" x 16"
6.75 lbs.

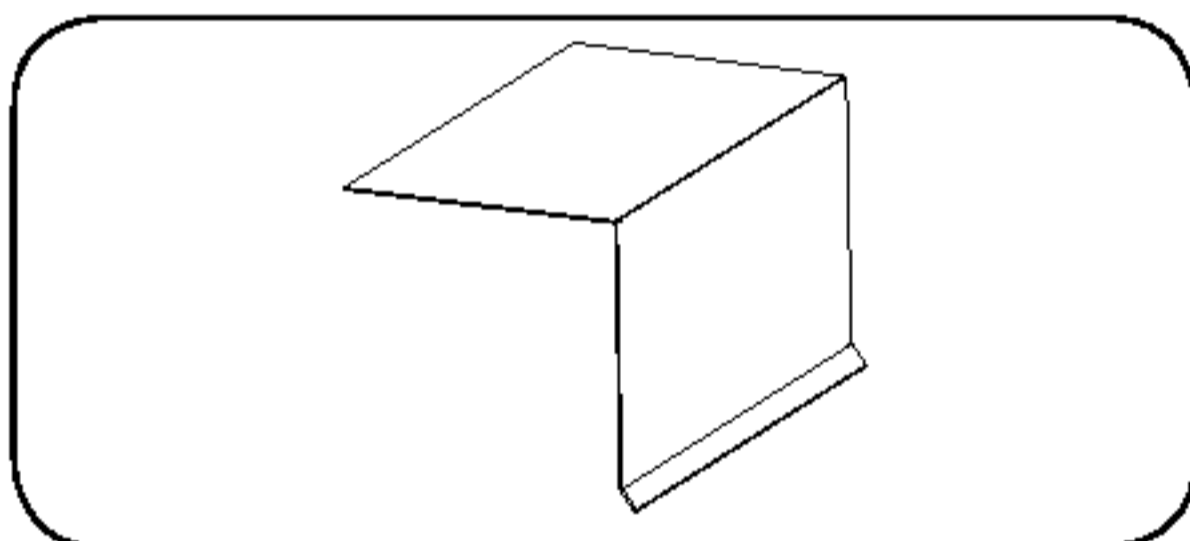

Drip Edge
120" X 2" X 1-1/2" - 1.0lbs.

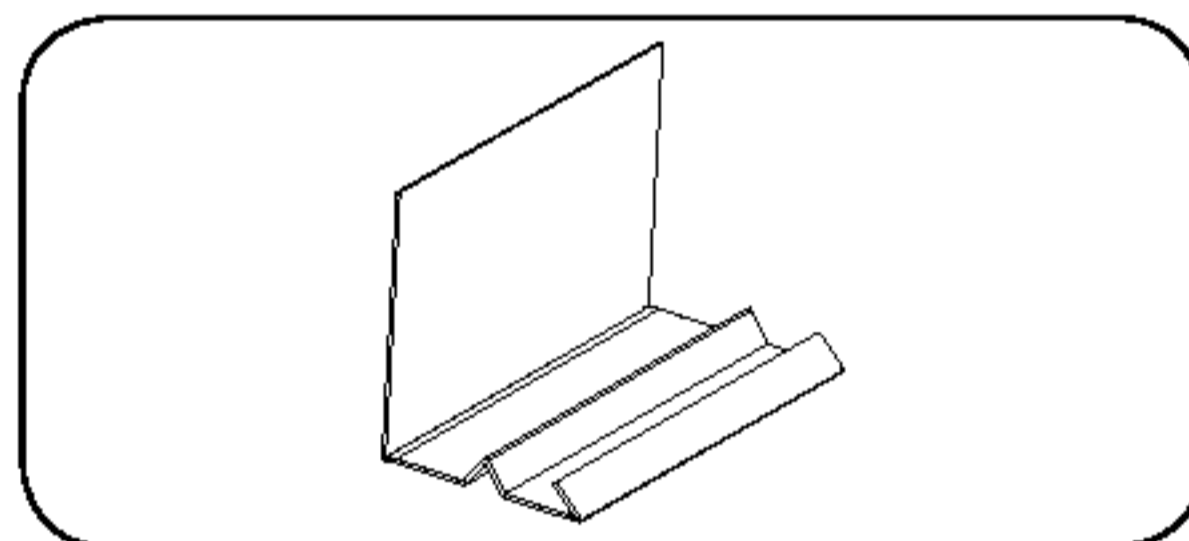

Side-Wall Under-pan metal
120" x 4"
5 lbs.



GENERAL

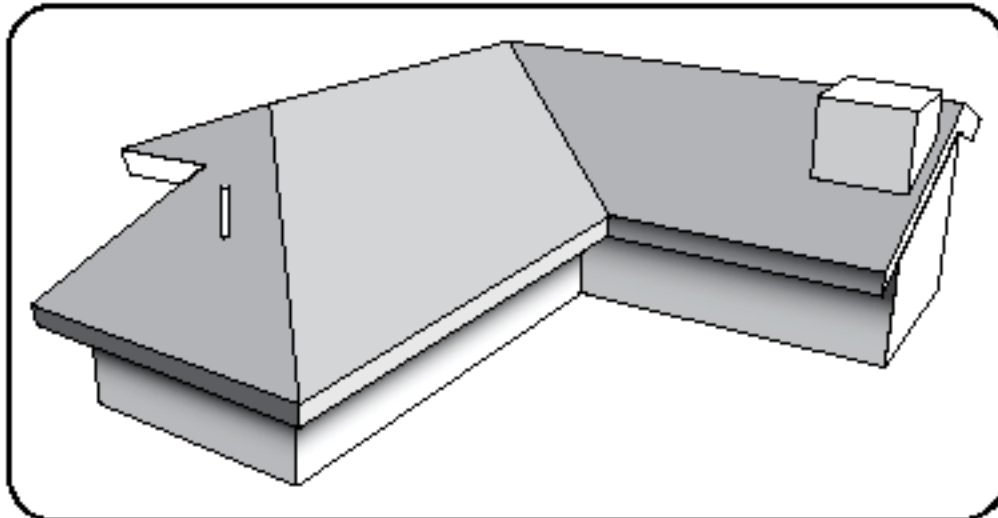

Metro Batten-less Shake panels are Installed on new or existing roofs pitched a minimum of 2-½ 12 (12 degrees). An underlayment is to be installed as per local code and manufacturers instructions.

DRIP EDGE

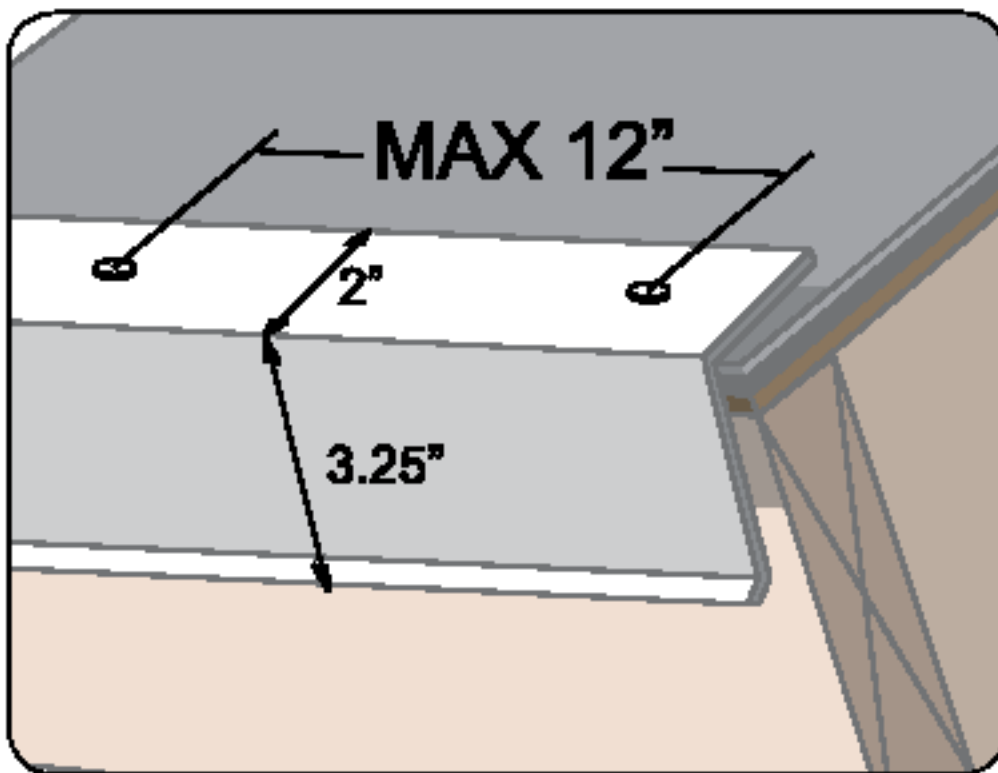

Install Drip Edge Metal across fascia. Drip Edge Metal may also be installed up Rakes when using Metro Rake Channel. If using Trim Caps on the Rake edges, install Metro Tile-Rake Metal edging up all rakes.

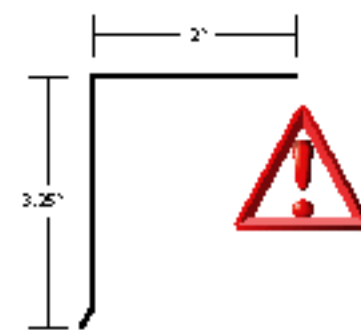

Florida and other high wind areas use the Metro FL-FASCIA Stone-Coated metal.

For HVHZ (High Velocity Hurricane Zone) areas, perimeter flashings are fastened per local code.

20" DOUBLE 'V' VALLEY

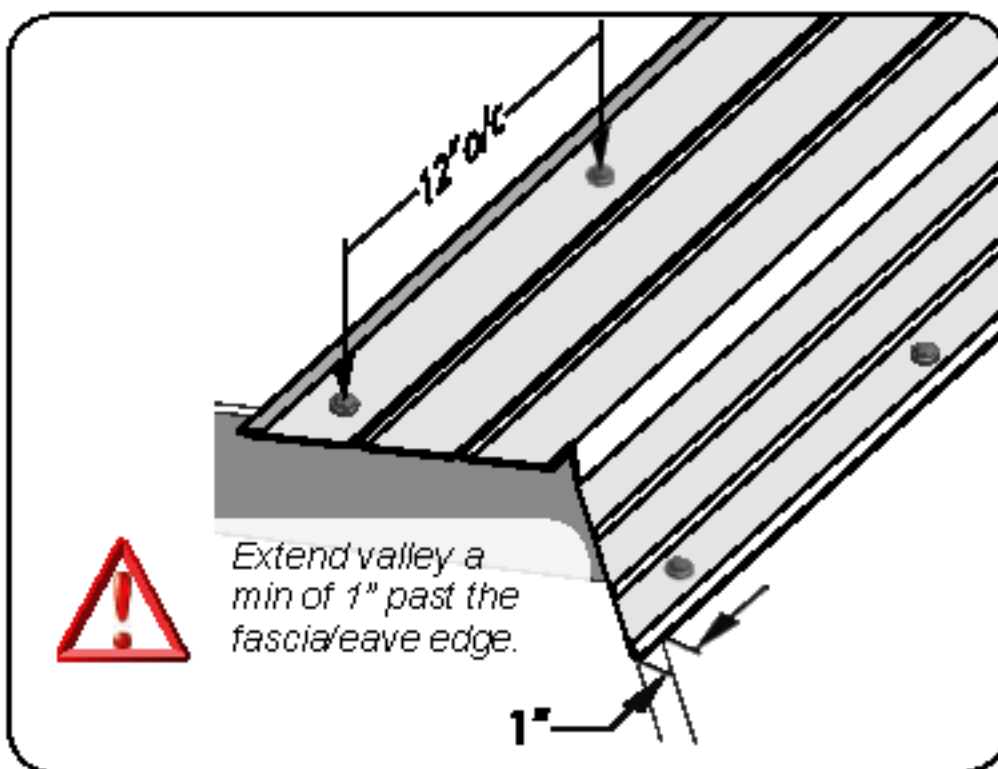

Install new 20" (508mm) Double V-Valley metal overlapping a minimum of 4" (100mm). Valleys are attached with washer & grommet screws in the outside locations as shown. Site fabricated clips may also be used to secure valley metal.



RISER METAL

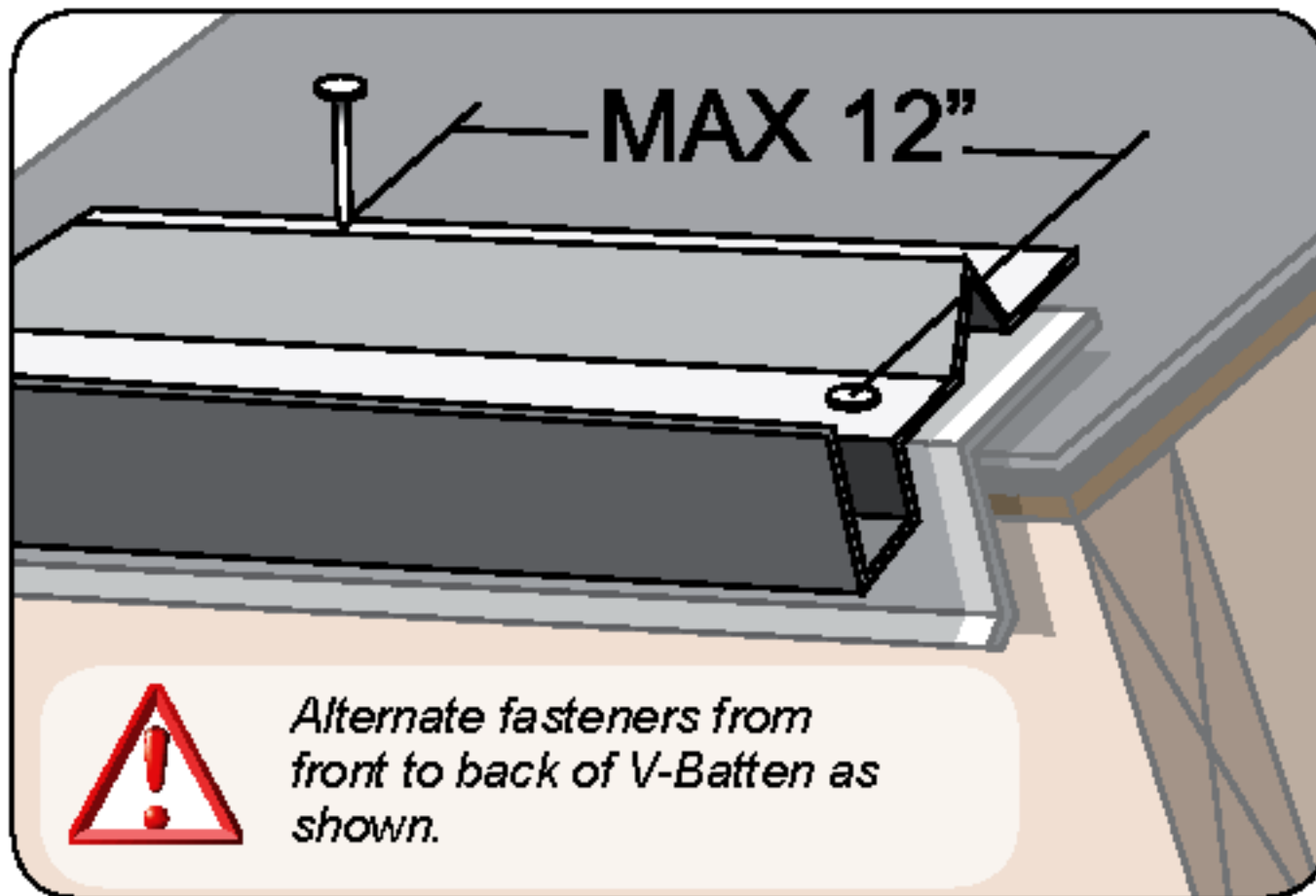

Use the V-Bat Riser Metal, which incorporates an integral "V" batten to provide panel support at the fascia. The V-Bat Riser Metal creates a 3/4" offset from the fascia. The use of this riser requires standard Drip Edge, or Metro FL-Fascia metal to be installed onto the roof deck first. When the V-Bat Riser Metal intersects a Rake Channel or Valley it must be notched and bent as shown to allow water to exit the roof.

RISER METAL - VALLEY METAL INTERSECTION

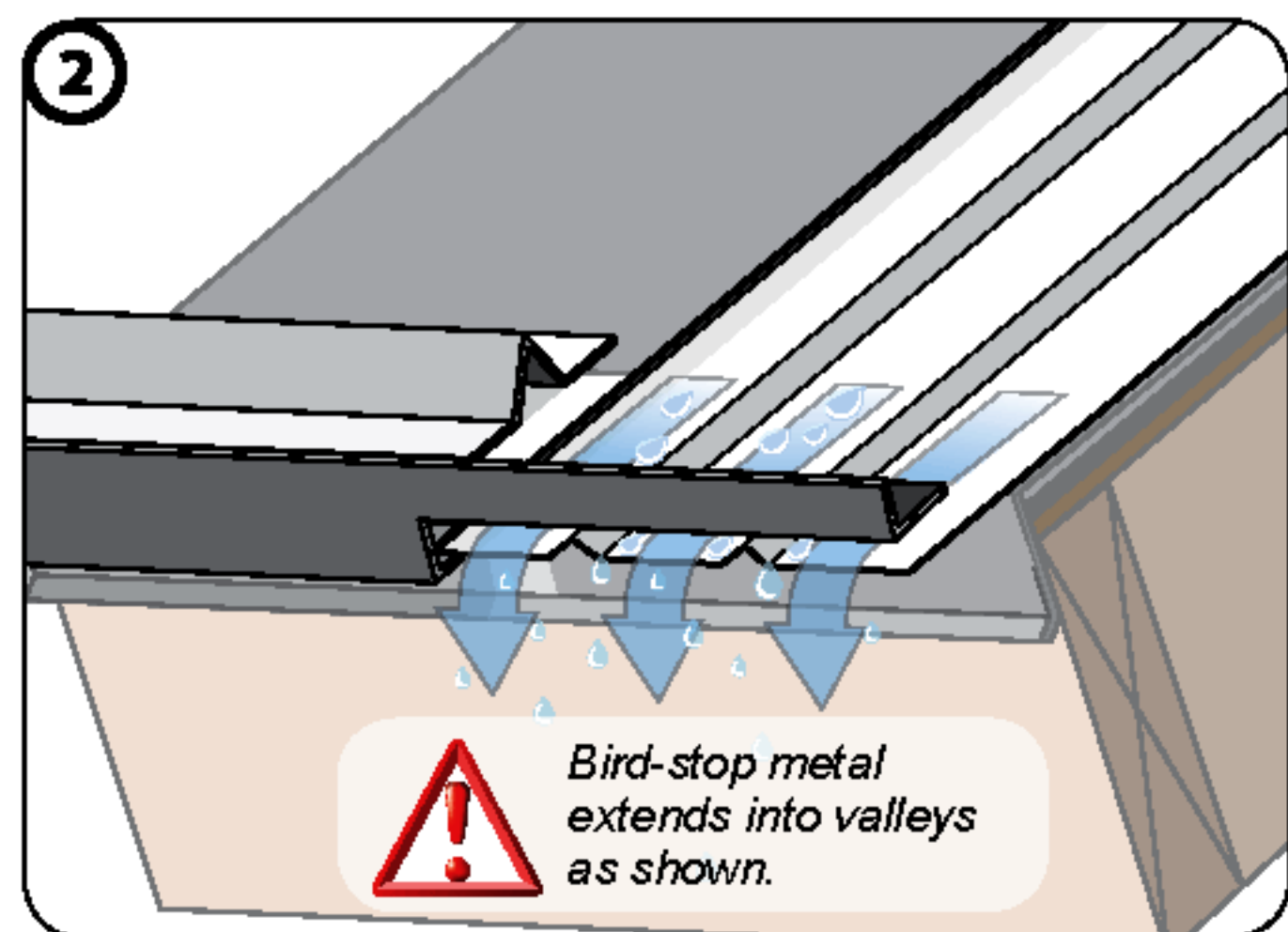
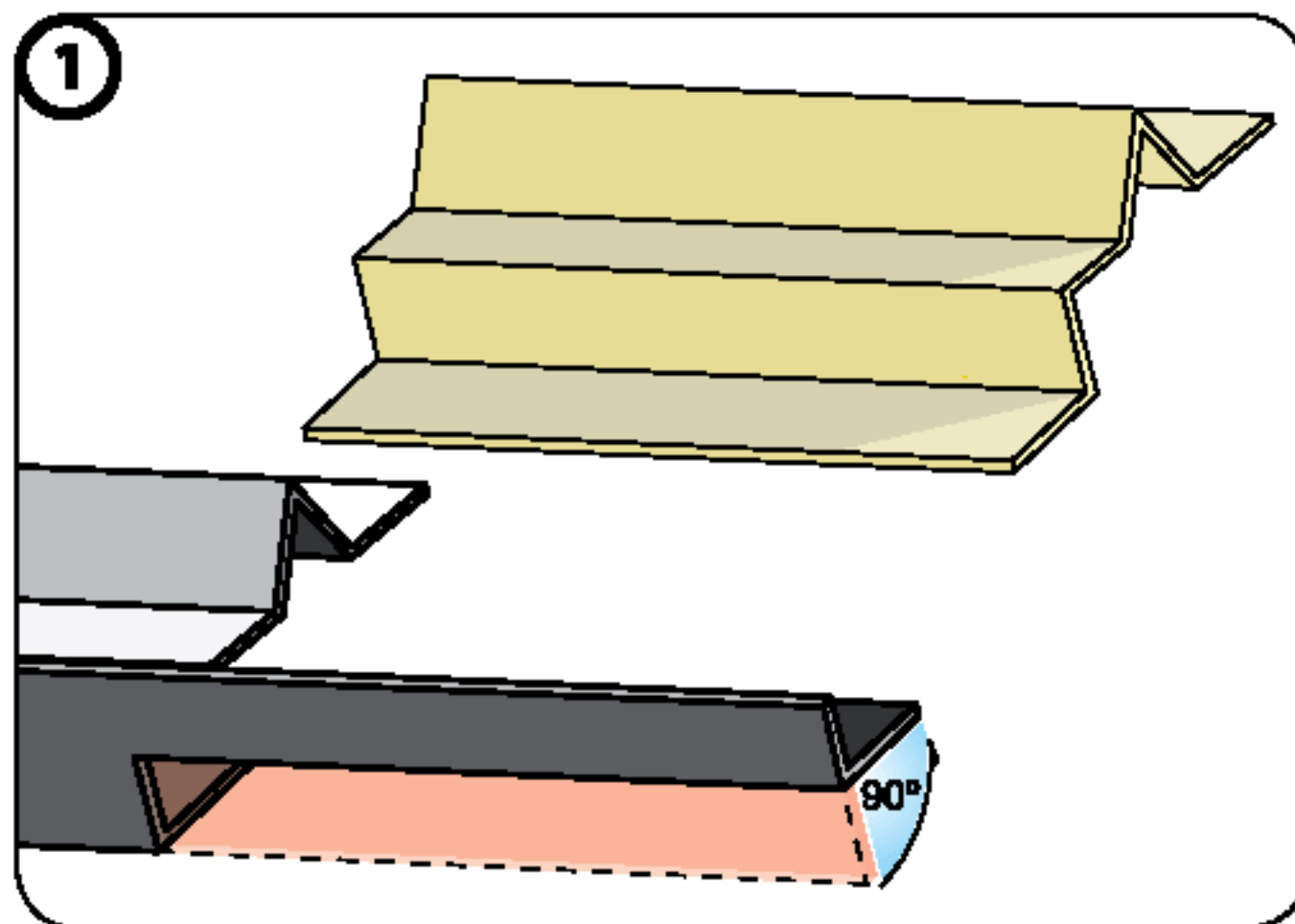

INTERNAL VALLEY CORNER NOTCHING DETAIL

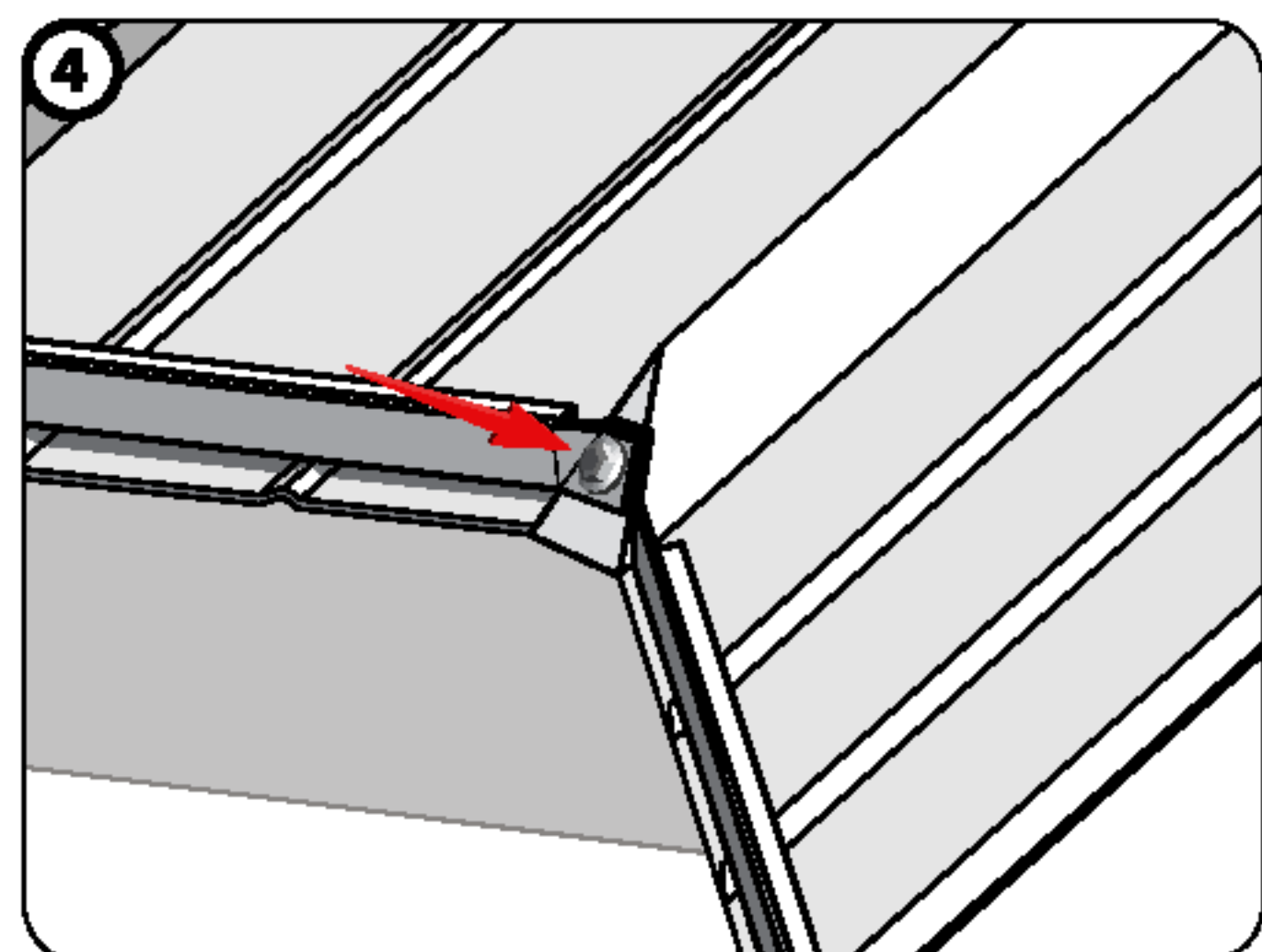
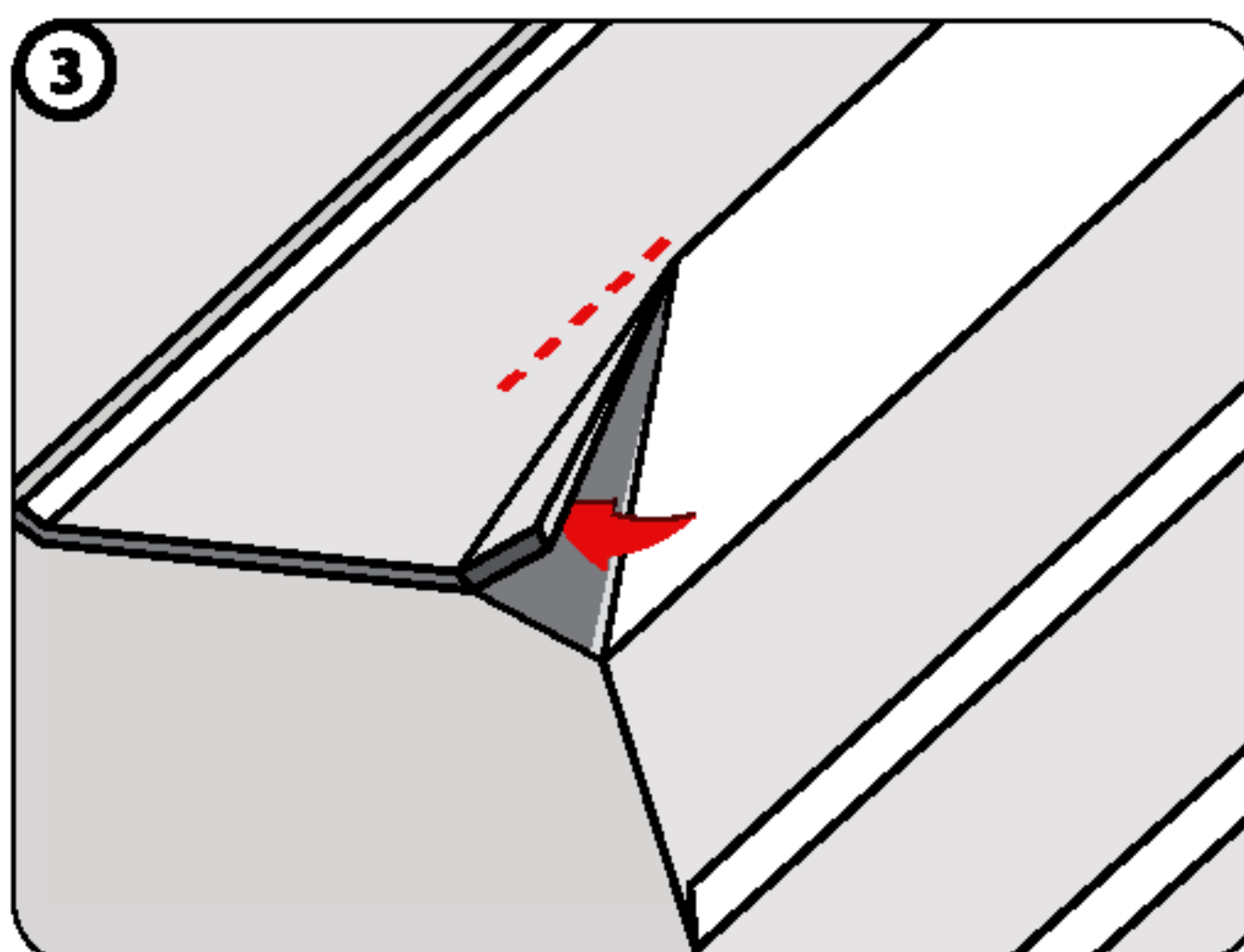

HIP & RIDGE BATTENS

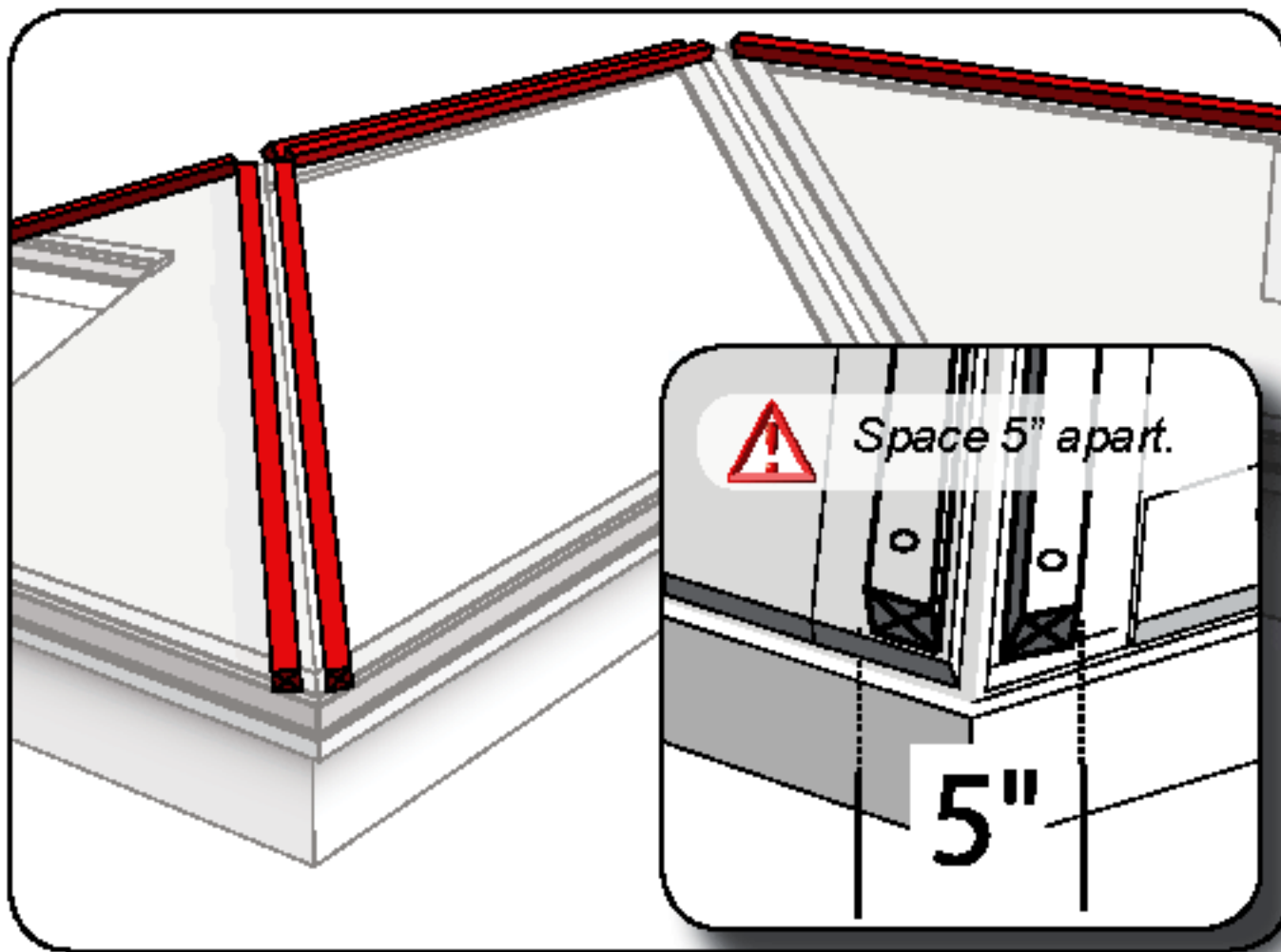

2"x2" ridge battens or double stacked 1"x4" pcs. are used to provide approximately 1½" of build-up height for hip and ridge pcs. Hip battens (2"x2" (50X50mm) are installed onto 1" X 4" (25X100mm) support battens as shown, so panels can be cut, bent & fitted against the battens.

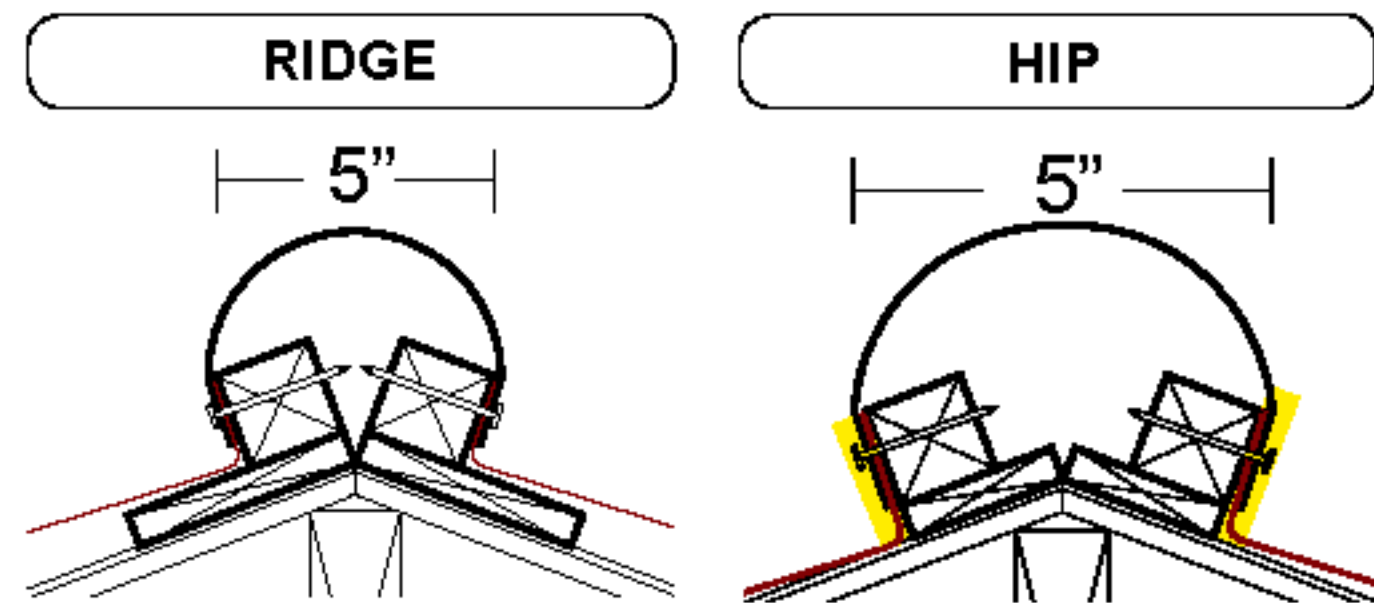

TILE RAKE METAL - TRIM CAPS UP RAKE

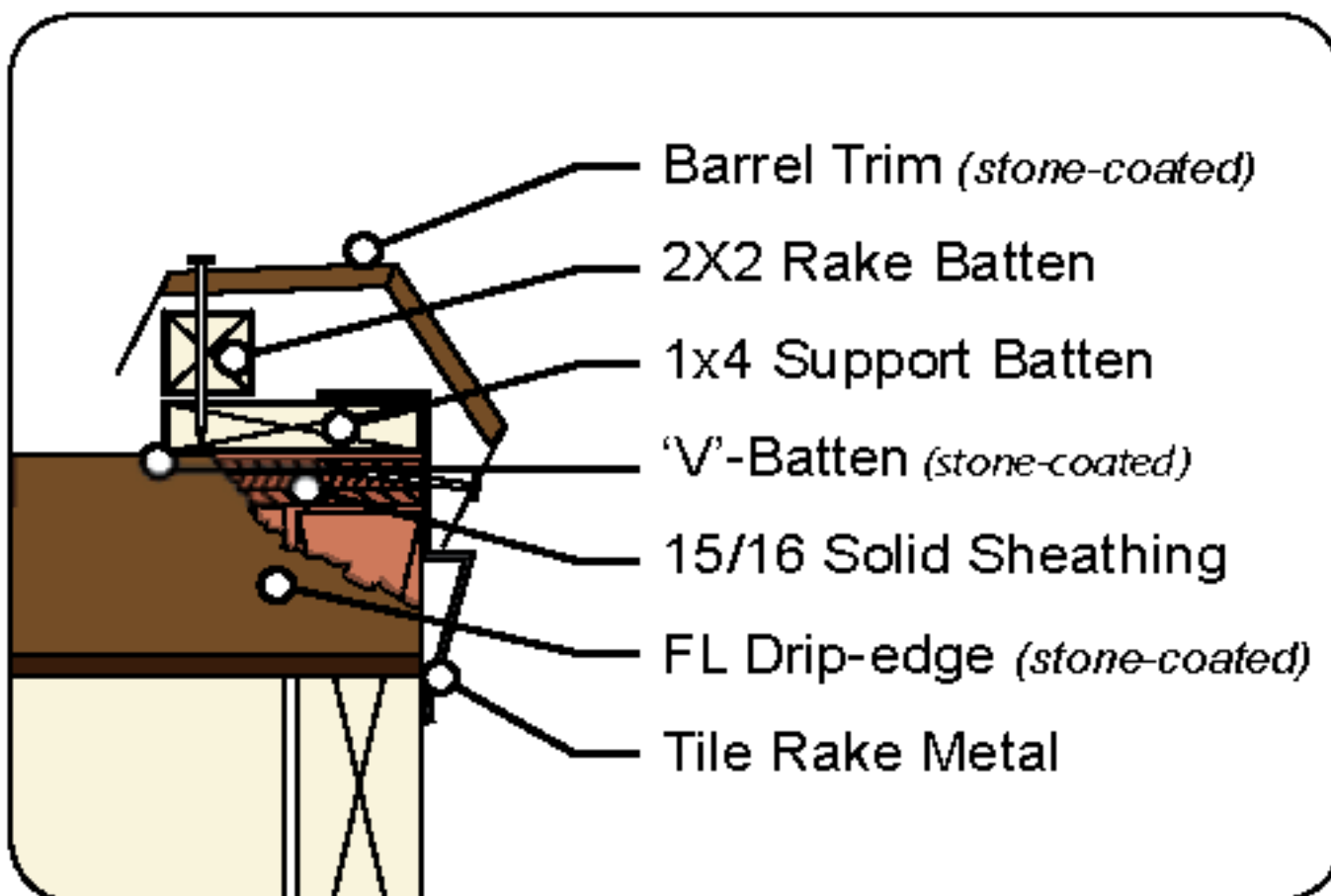

Metro Tile Rake Metal is installed along rake edges as shown. This rake edge metal aids in the alignment of Metro Trim Caps. The Metro Trim Caps install over the rake build-up and folded-up Metro panels.

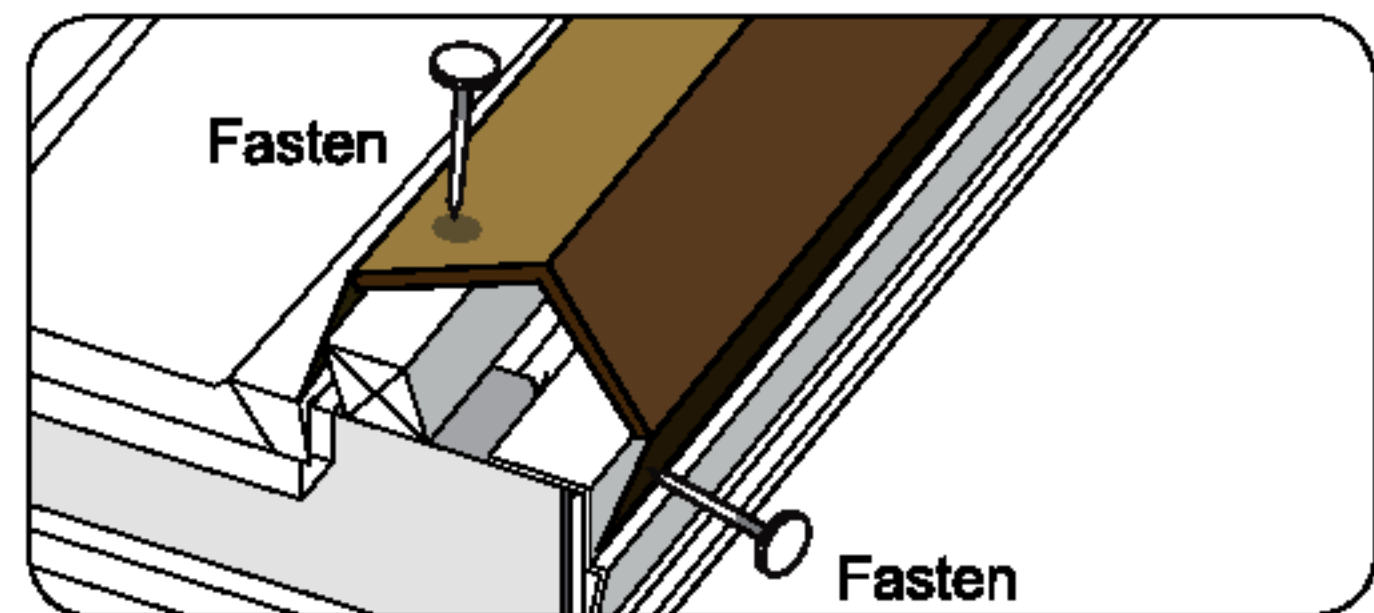

RAKE METAL

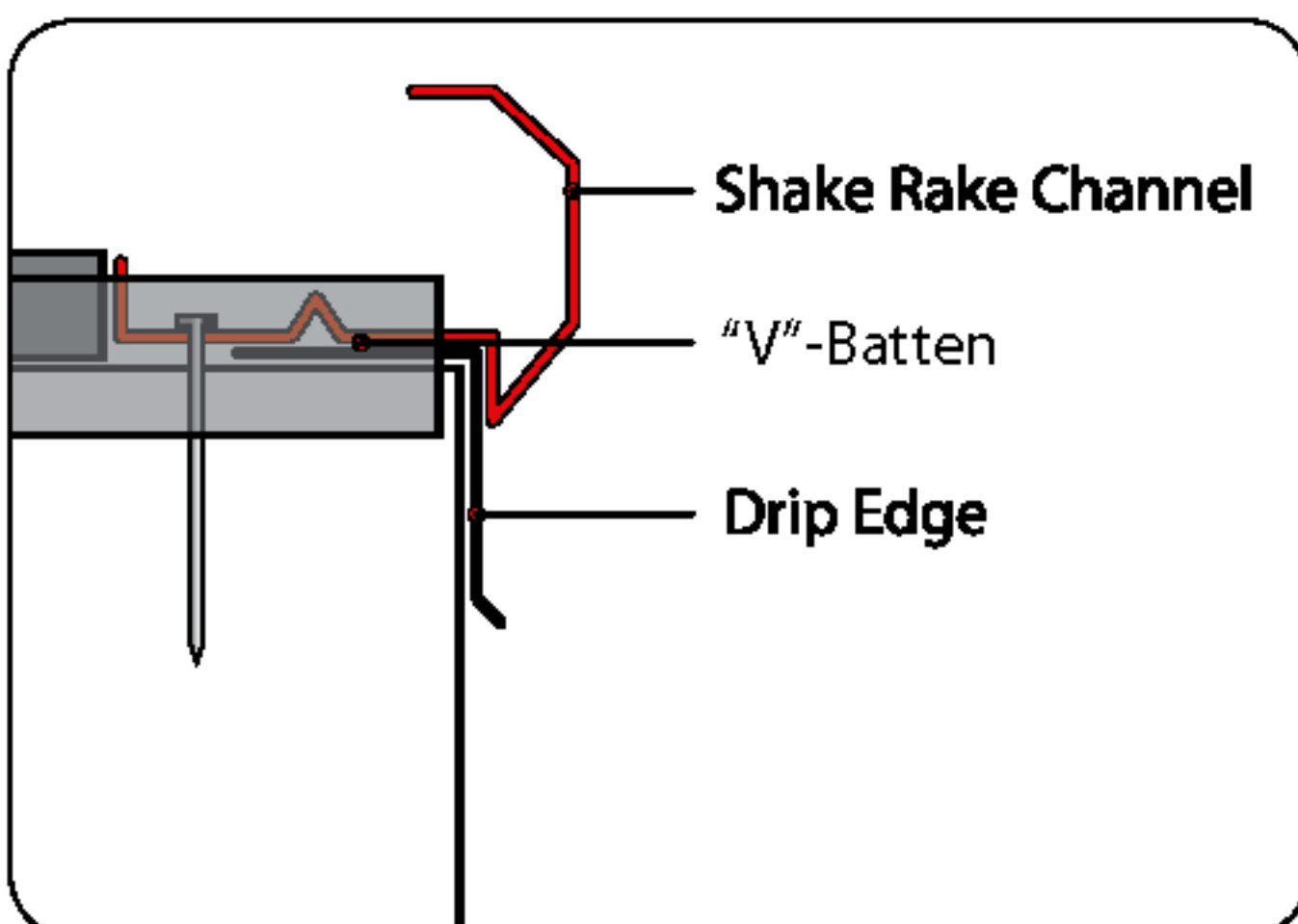

Install Metro panels over Drip Edge using fasteners placed in the outside channel as shown. If fasteners do not have a sealing washer, apply a bead of sealant around each one. Rake metal is notched to lap at joints a minimum of 2" (50mm) overlap in water channels.

 **Lap 2" (50mm) minimum to prevent leakage through seams.**

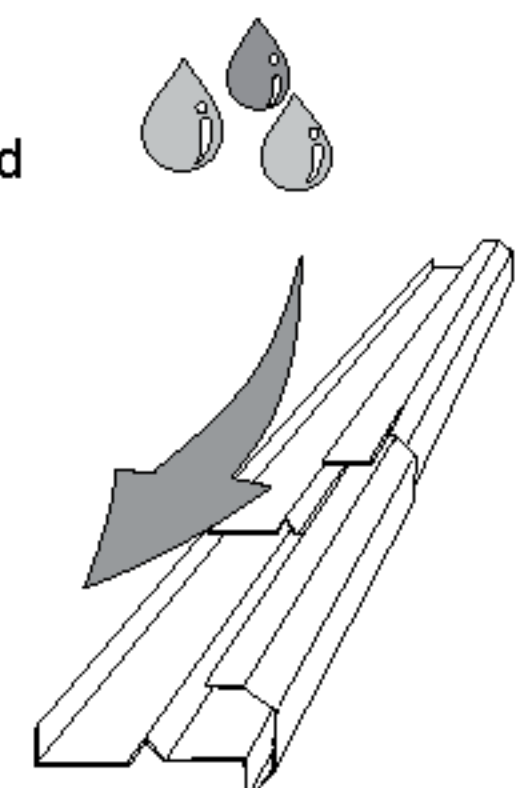

STANDARD FASTENING SEQUENCE

Fasten panels in sequence as shown, failure to follow this procedure may result in panels being misaligned.

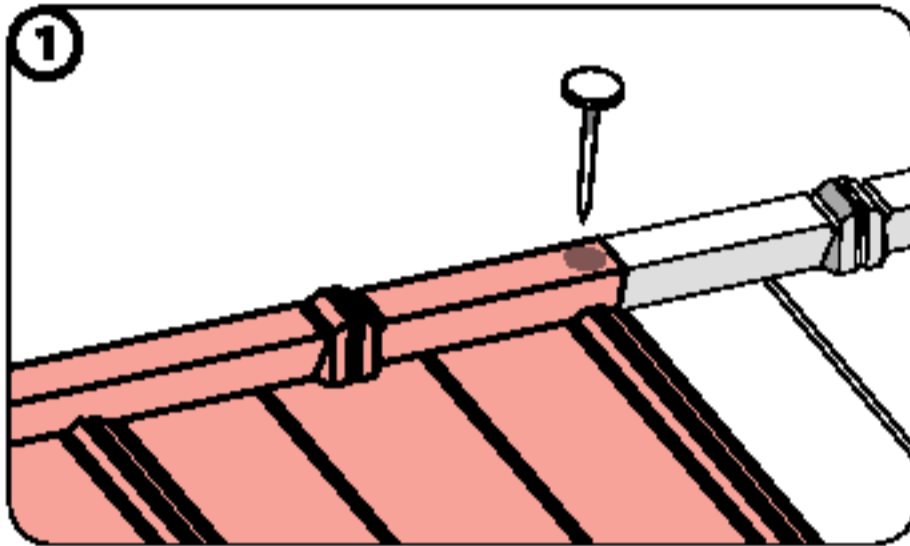

Fasten top right corner

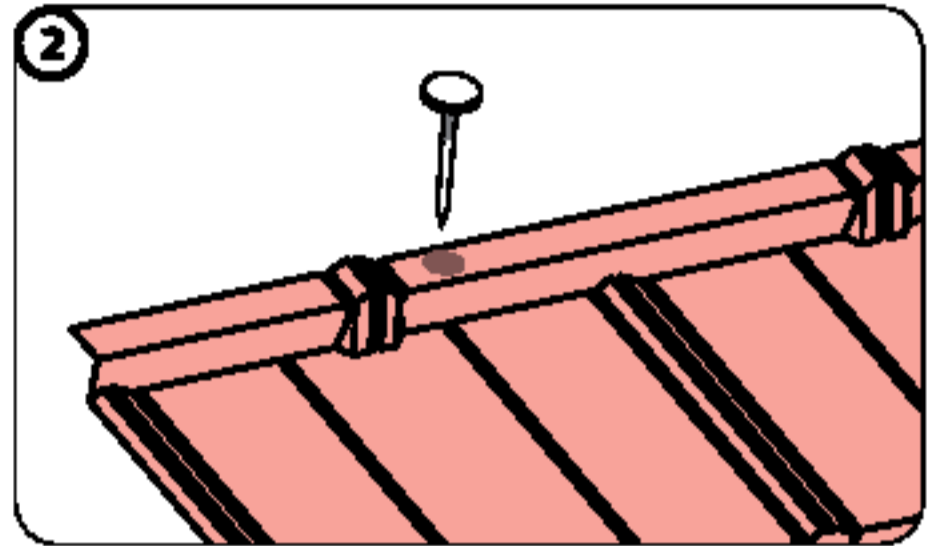

Fasten top left corner

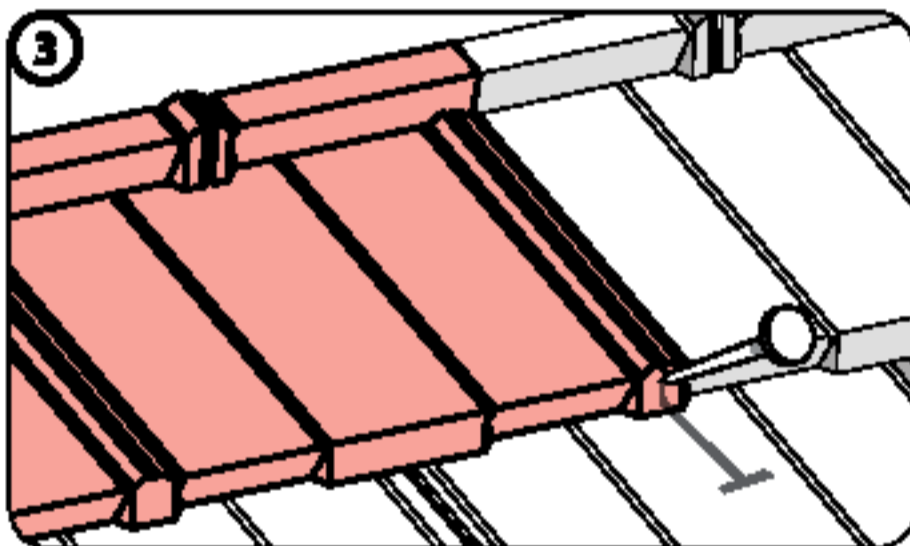

Fasten bottom right corner

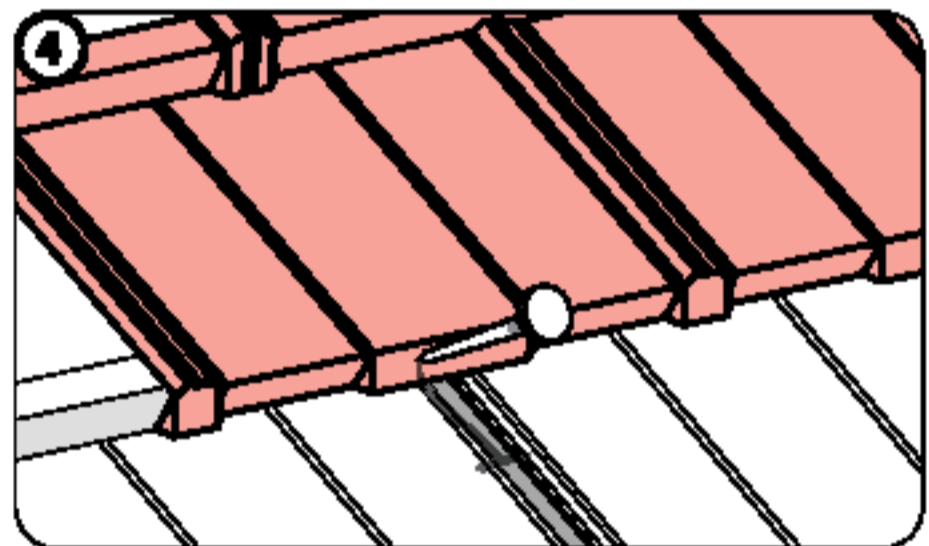

Fasten bottom left corner.

PANEL LAYOUT

MetroSHAKE™ panels have a 2" (50mm) side-lap and two staggered locating points along the back of each panel as shown.

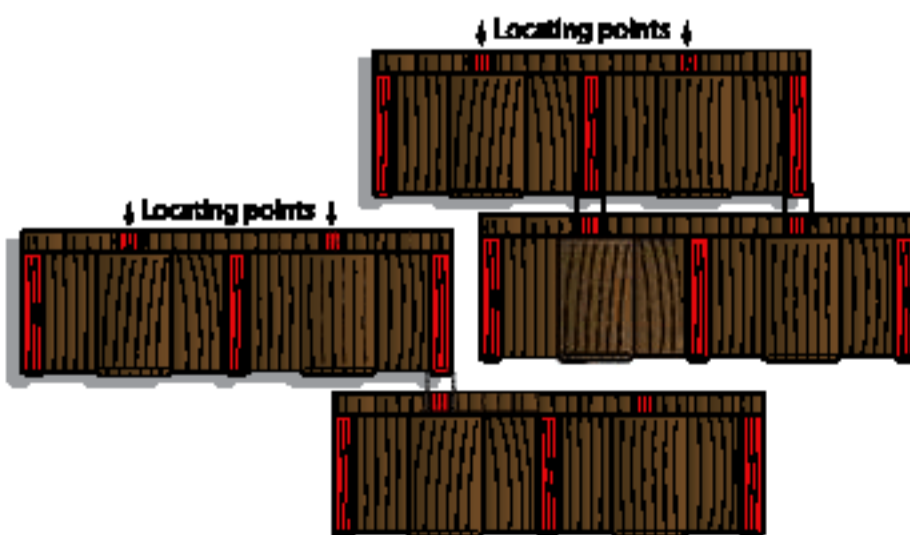

Shake panels are staggered and placed according to their locating points.



MetroSHAKE™ panels cannot be straight laid



HVHZ FASTENING LOCATIONS

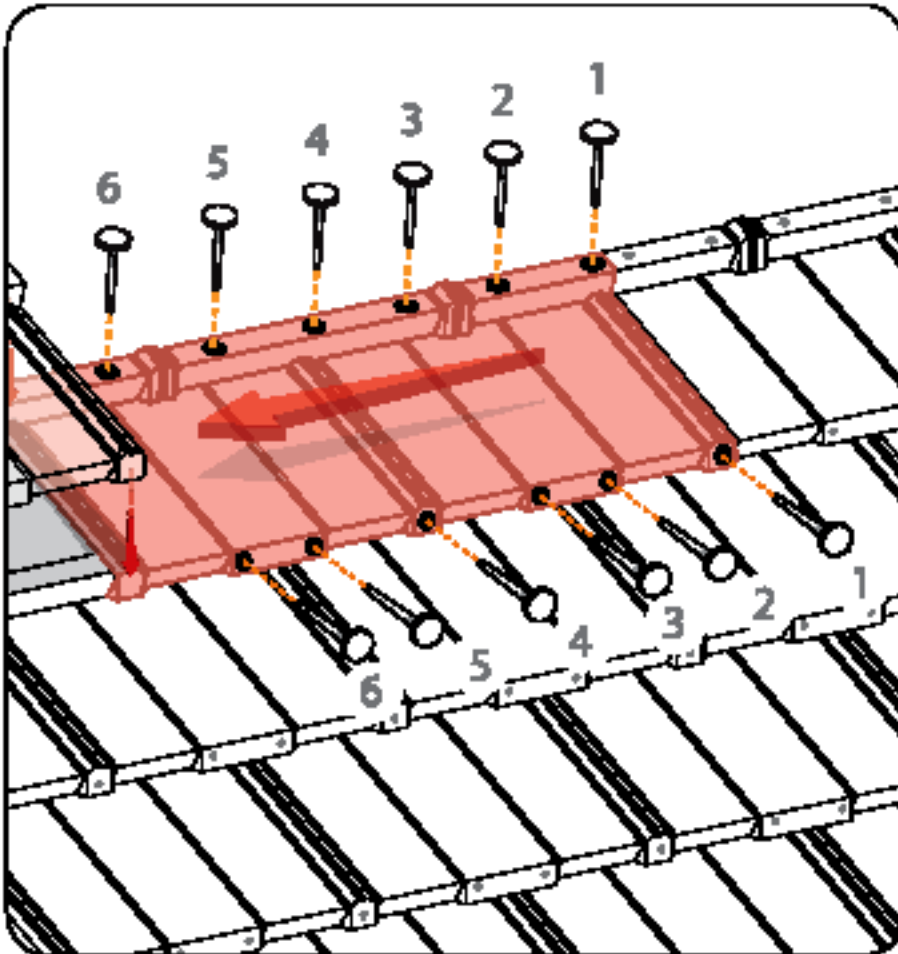

Refer to Metro's High Velocity Hurricane Zone (HVHZ) fastening details found in Metro's Florida Building Code HVHZ Approval FL-6710 for details.

NOTE:

A) When installing panels on BATTENS, only the nose fasteners are used in each panel.

B) Fastener location is approximate and should be located out of main water channels.

C) Assumes panels are laid Right to Left.

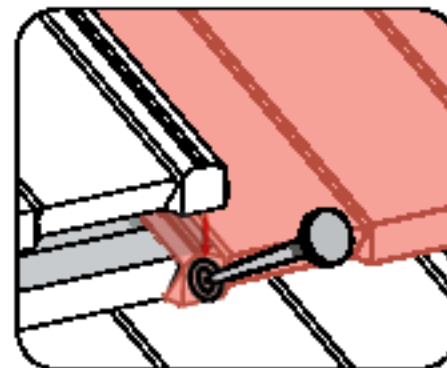

HVHZ FASTENING SEQUENCE

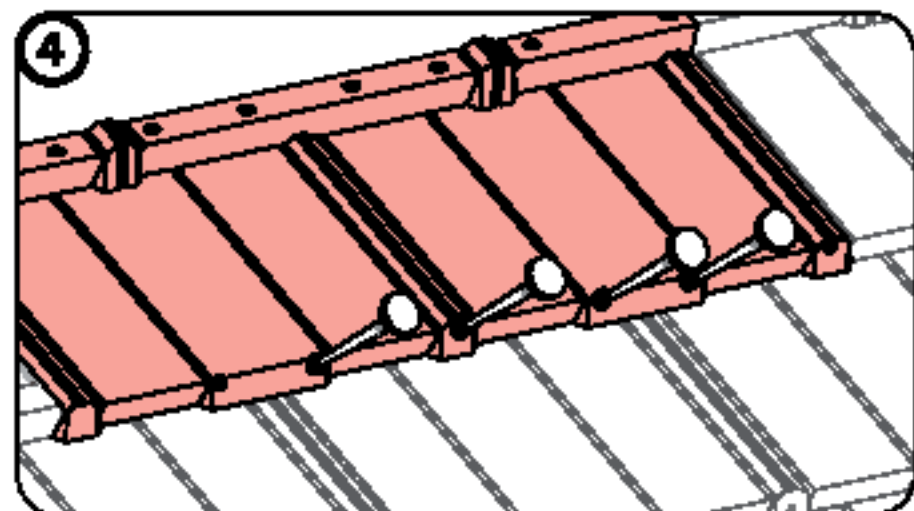
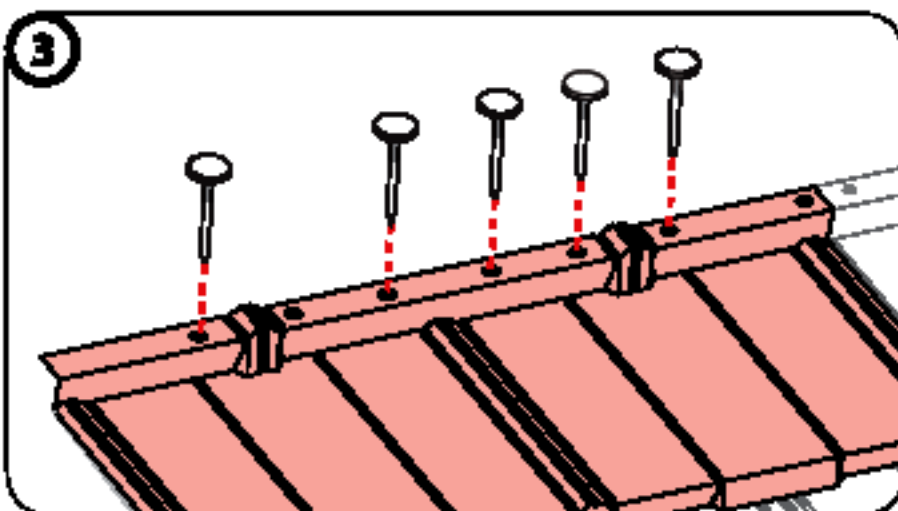
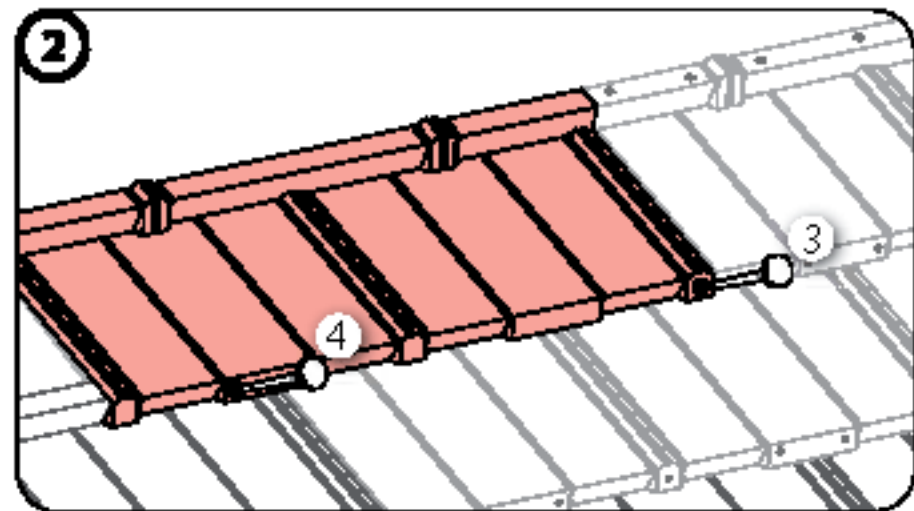
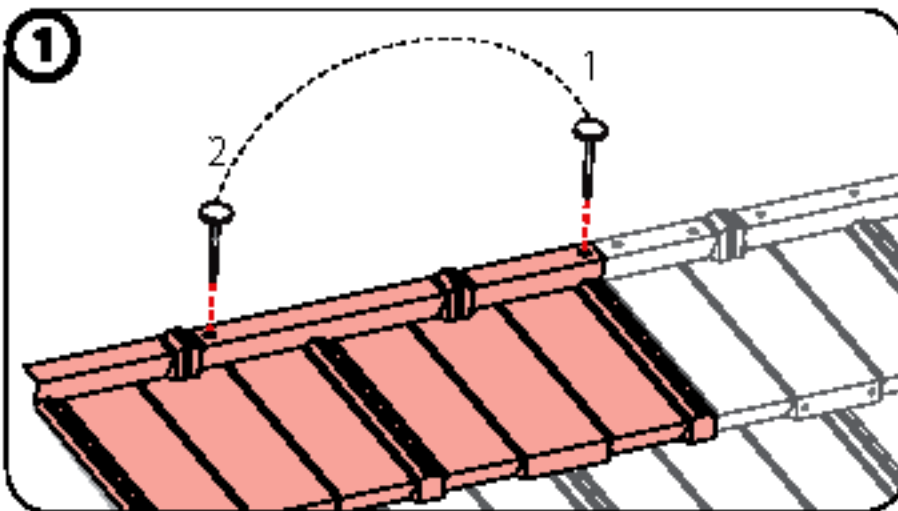

FASTENING LOCATIONS - NAILS

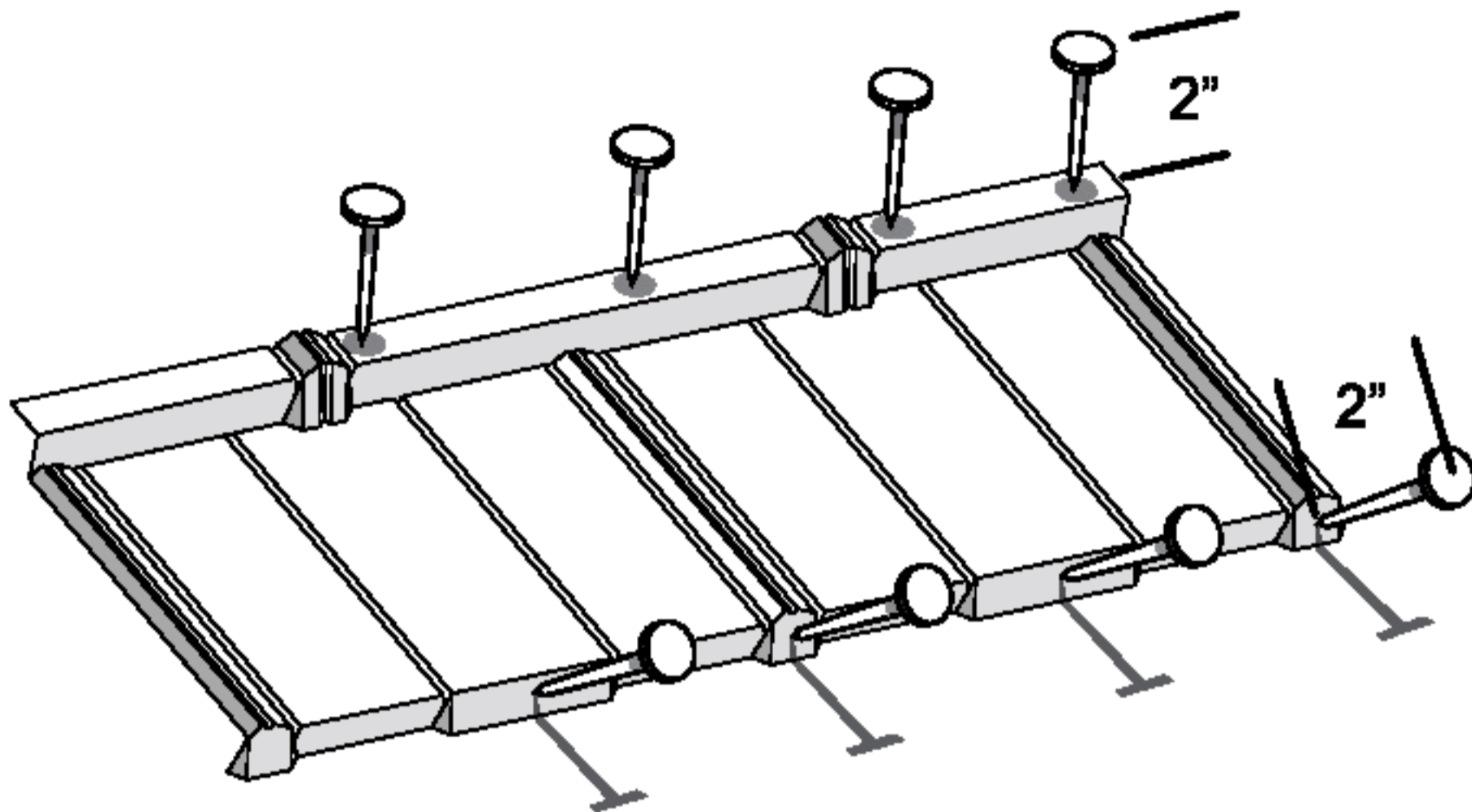

The "Standard" fastening pattern for Metro Batten-Less panels uses four (4) fasteners across the back flange and four (4) across the front nose down-turn.

All fasteners used on a Metro roof shall meet or exceed the corrosion resistant standard as defined in ASTM B-117, (1,000hr minimum Salt Spray Corrosion Resistance).

Panel, Trim & Accessory fasteners shall be as follows:

NAILS:

.131" dia X 2-3/8" long Ring Shank & coated Black.

 Details shown below utilize a stick nail-gun with a special 'Nose Fastener-Angle' device attached. Contact Metro for information regarding this item.

FASTENING BATTEN-LESS SHAKE PANELS - NAILS

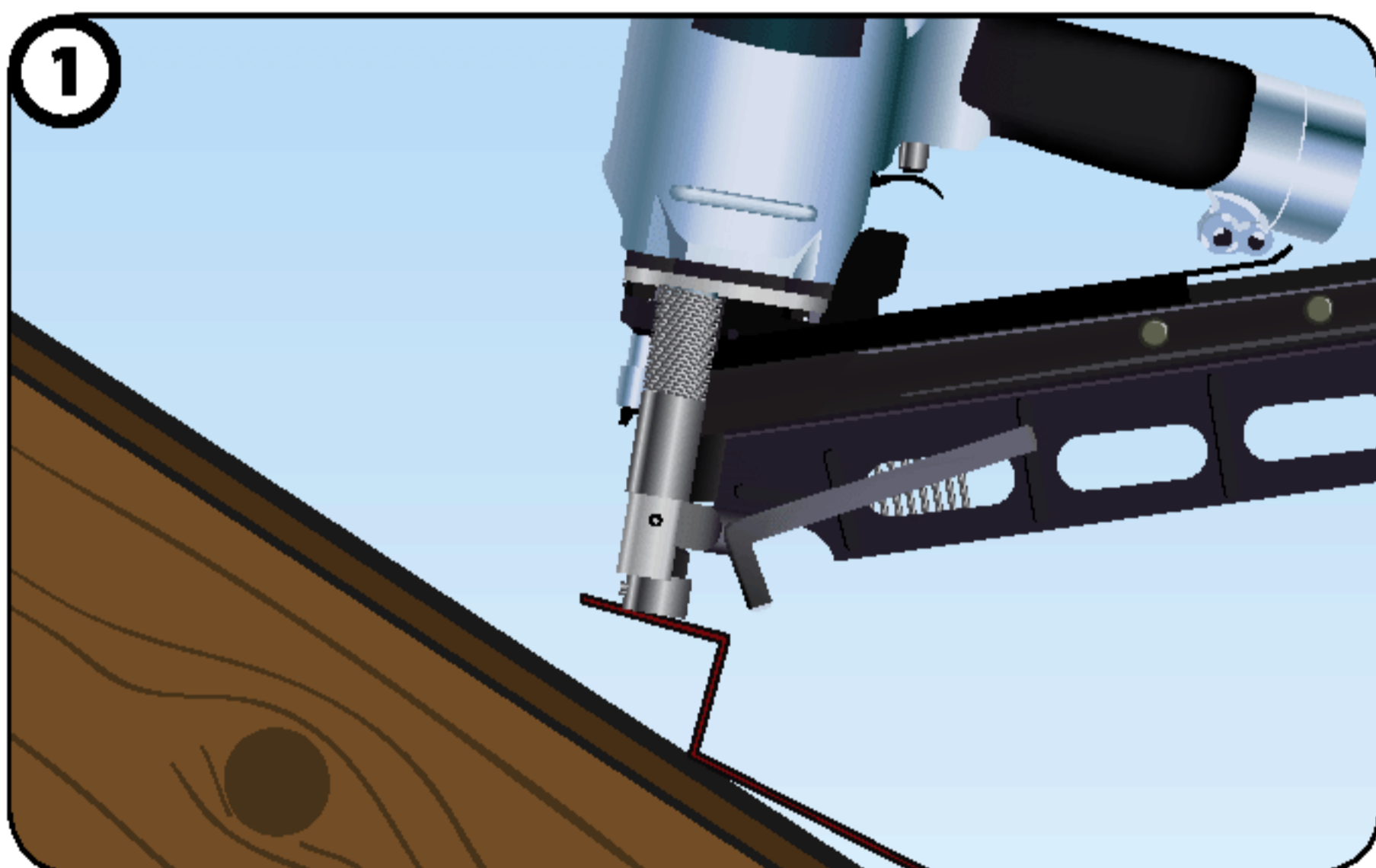

1 Panel back flange is fastened vertically into roof deck.

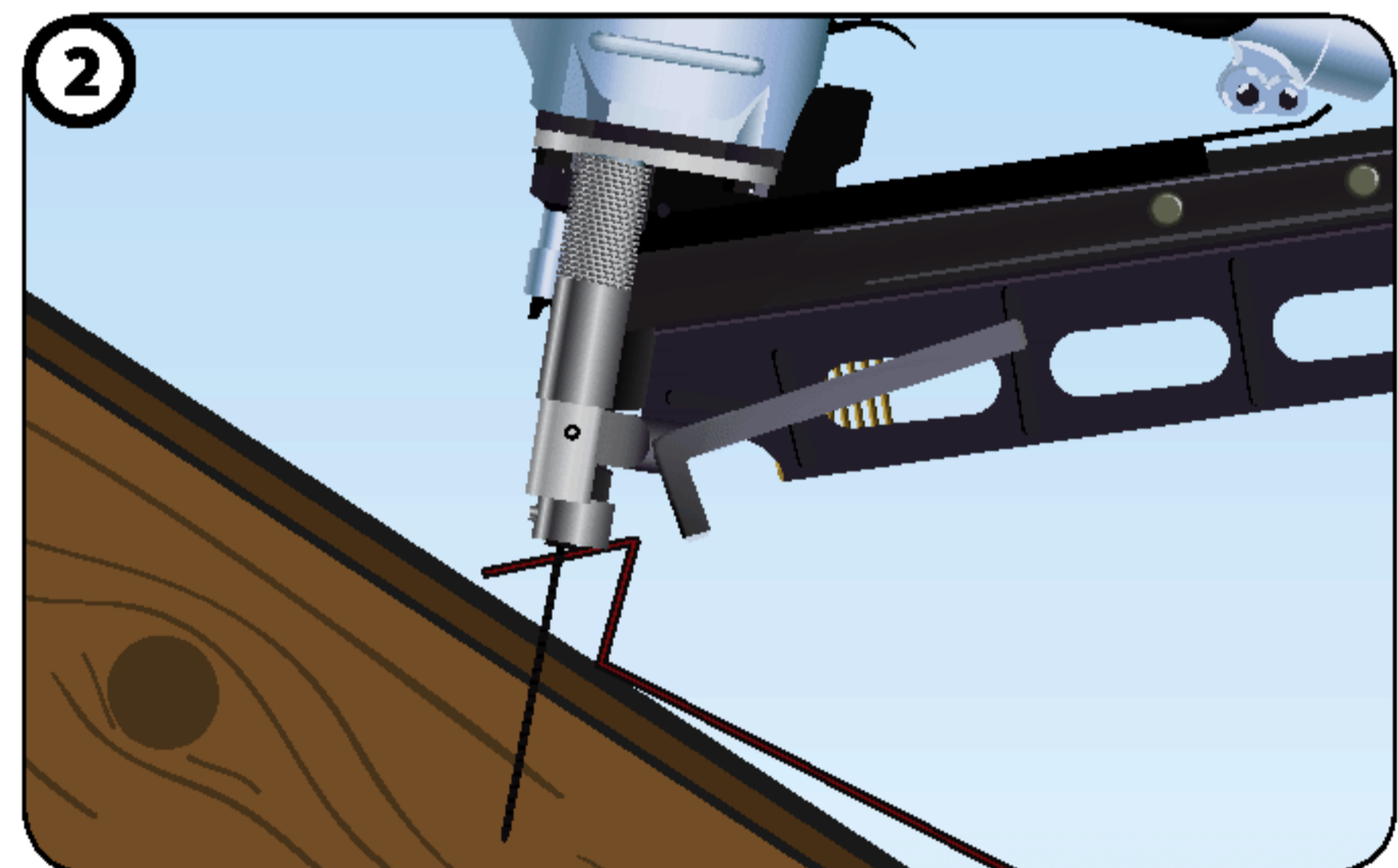

2 Back Flange is seated down onto roof deck.

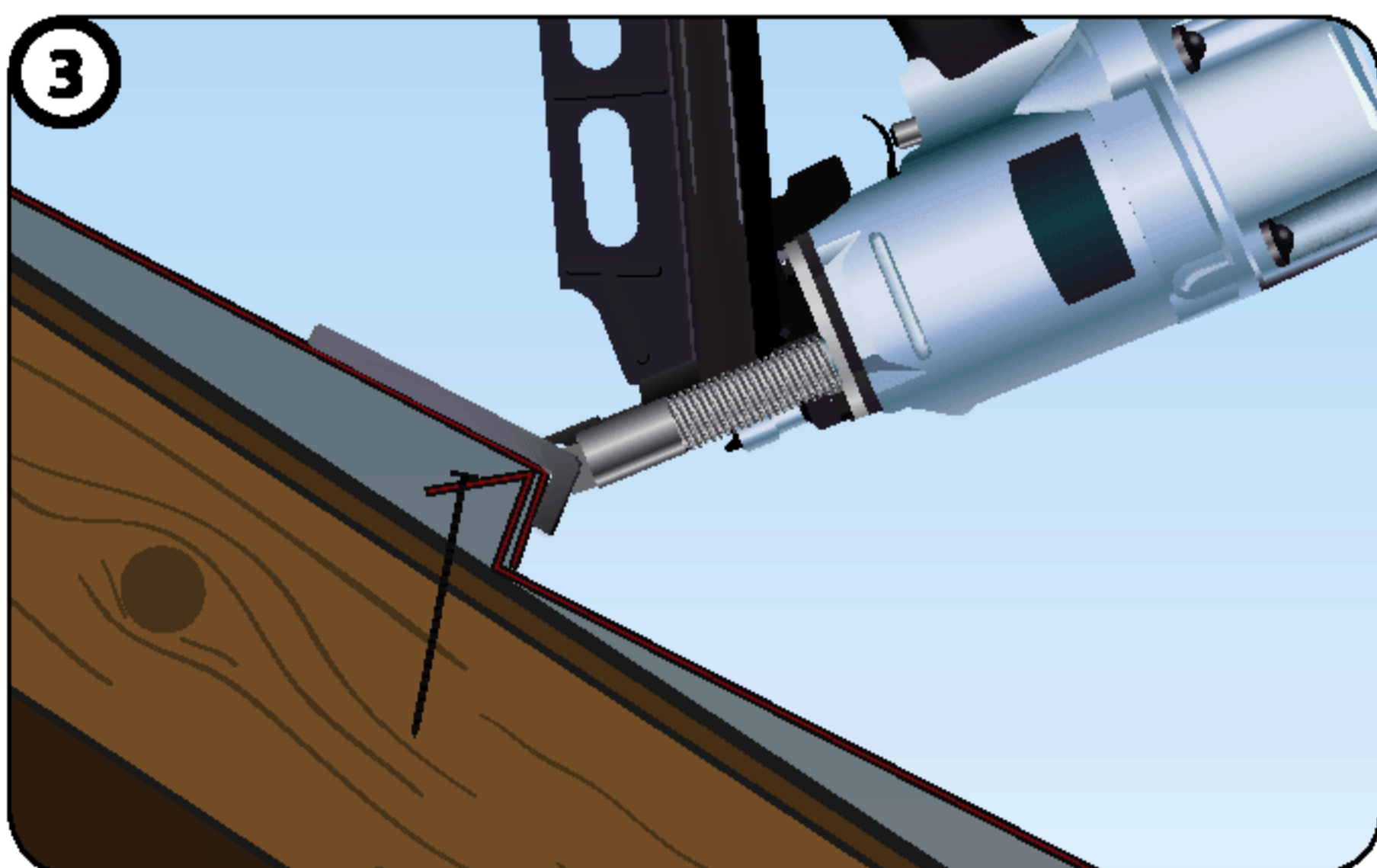

3 Install nose fasteners at an approximate 60-degree angle.

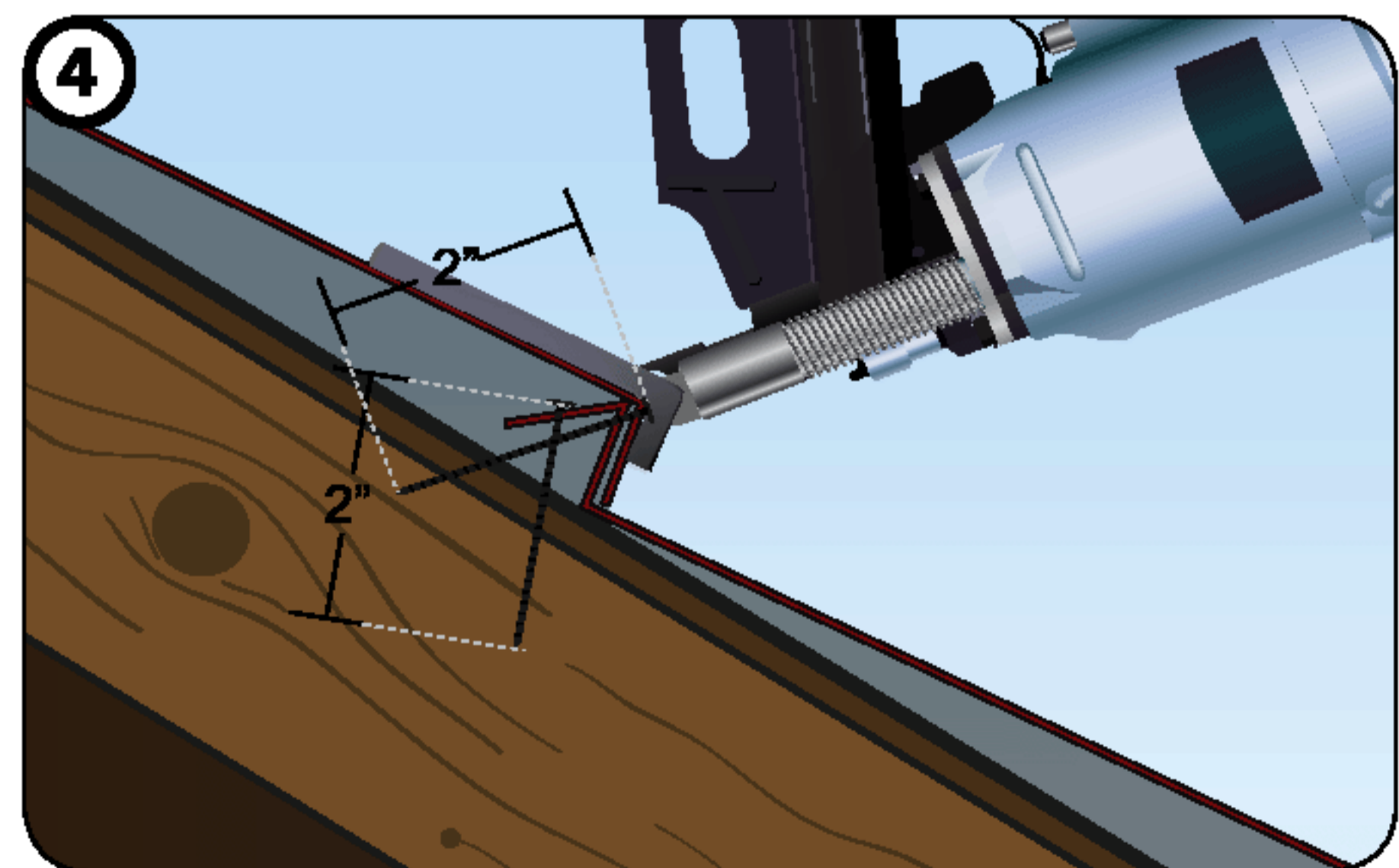

4 Use of the nail-gun attachment ensures correct nose-nail fastener angle.

FASTENING LOCATIONS - SCREWS

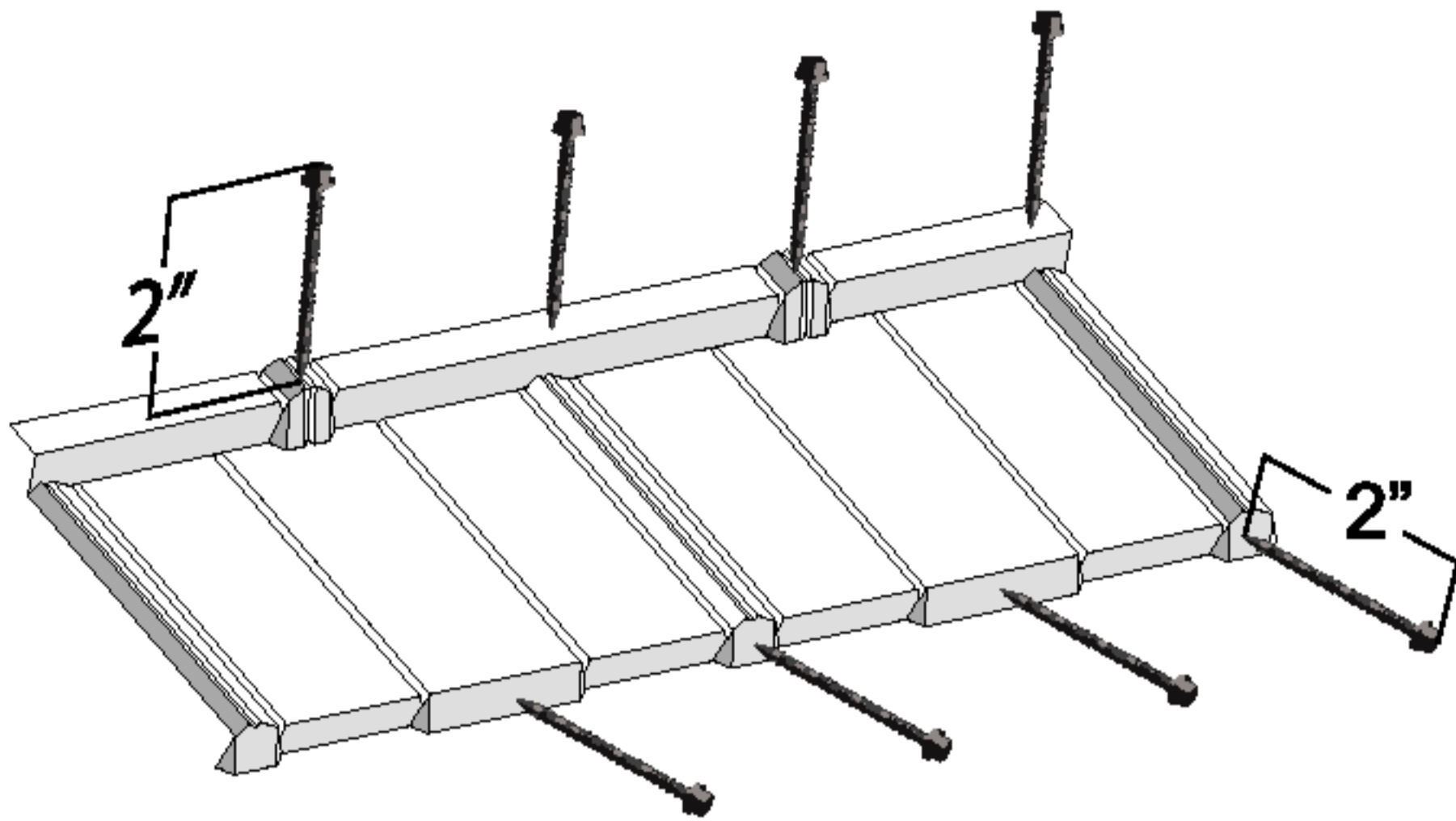

The "Standard" fastening pattern for Metro Batten-Less panels uses four (4) fasteners across the back flange and four (4) across the front nose down-turn.

All fasteners used on a Metro roof shall meet or exceed the corrosion resistant standard as defined in ASTM B-117, (1,000hr minimum Salt Spray Corrosion Resistance).

Panel, Trim & Accessory fasteners shall be as follows:

SCREWS:

#10- 2" or 2-1/2" long, 1/4" Hex Head.

FASTENING BATTEN-LESS SHAKE PANELS - SCREWS

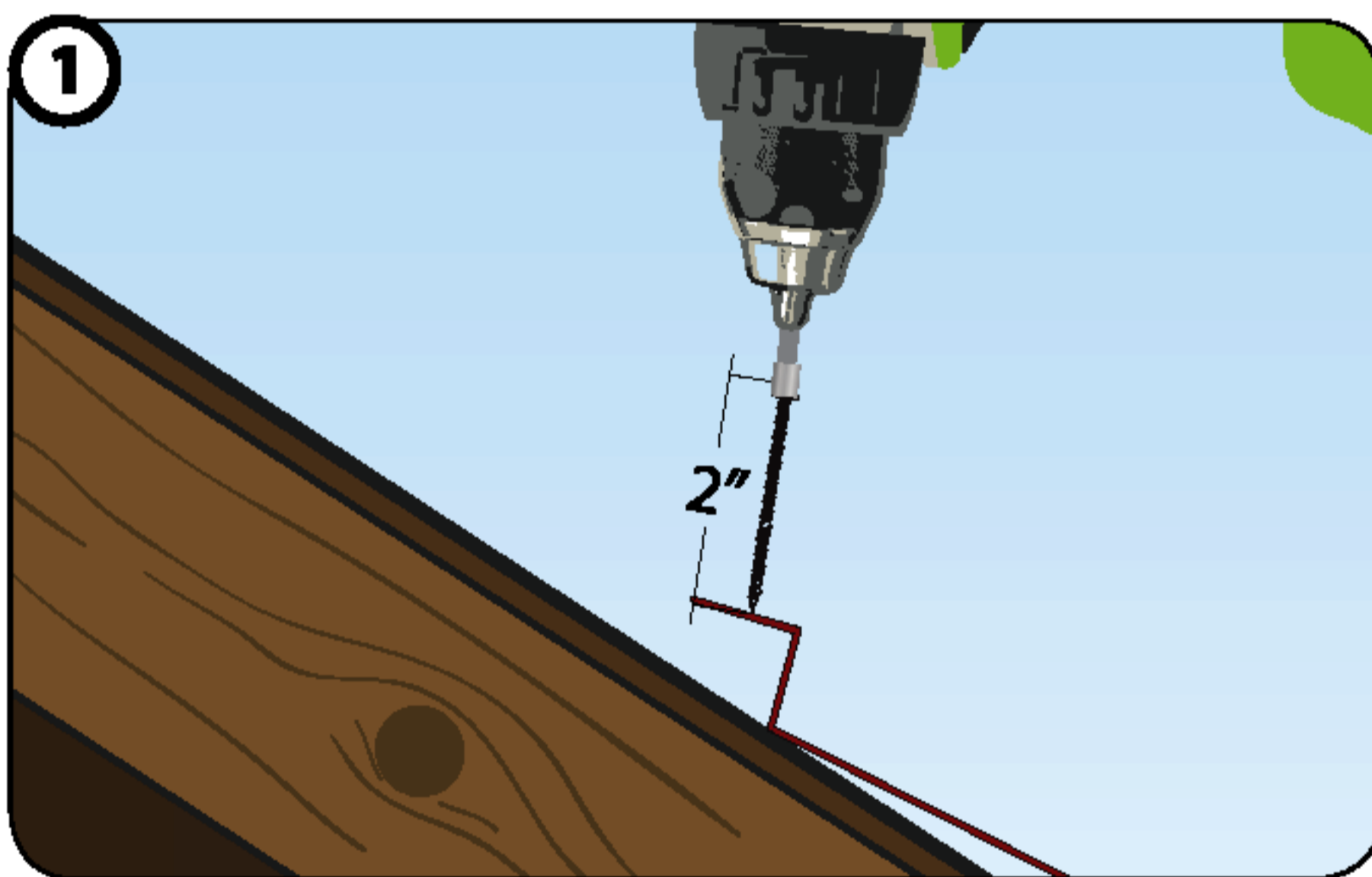

1 Panel back flange is fastened vertically into roof deck.

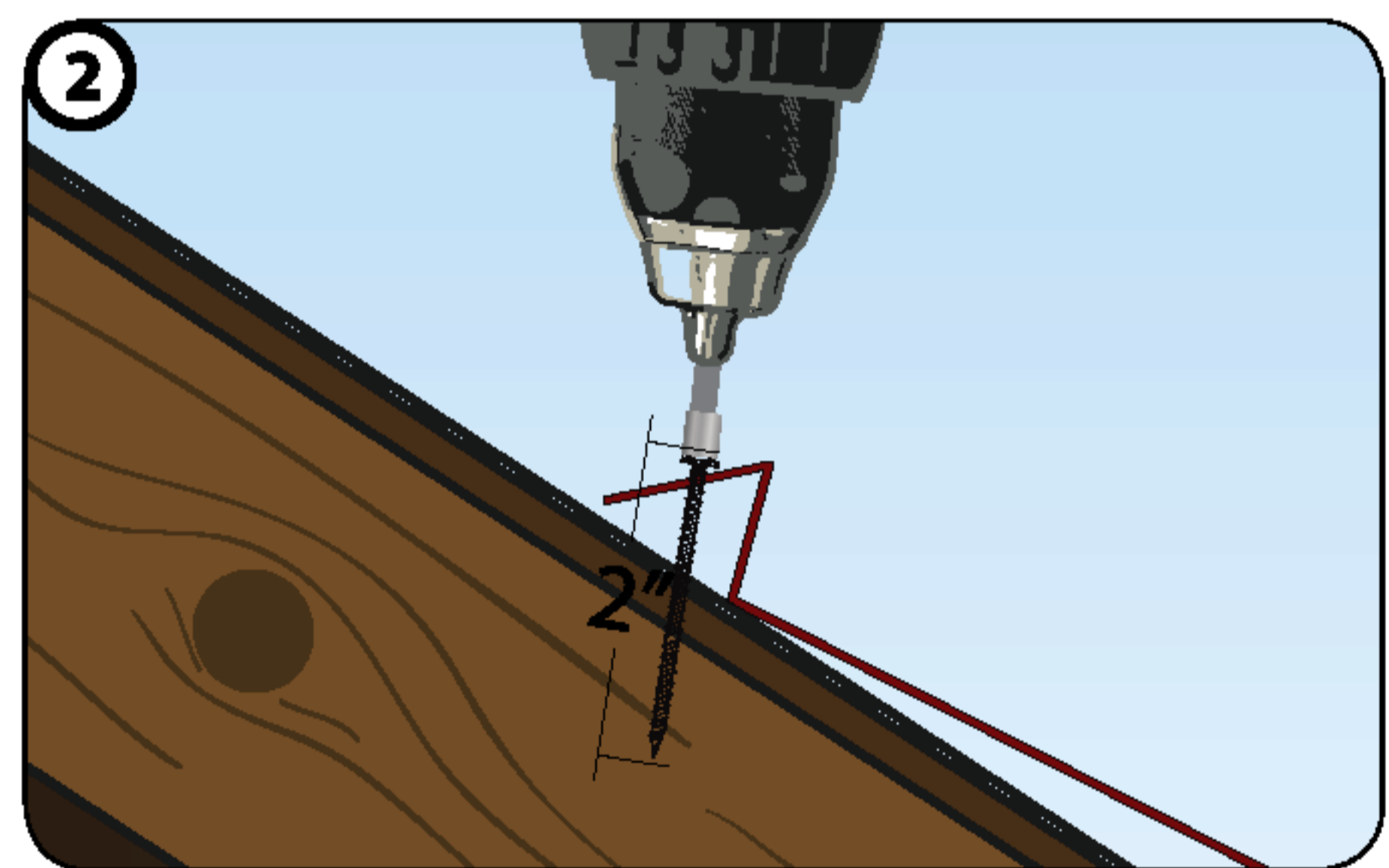

2 Panel back flange is 'seated' down onto roof deck.

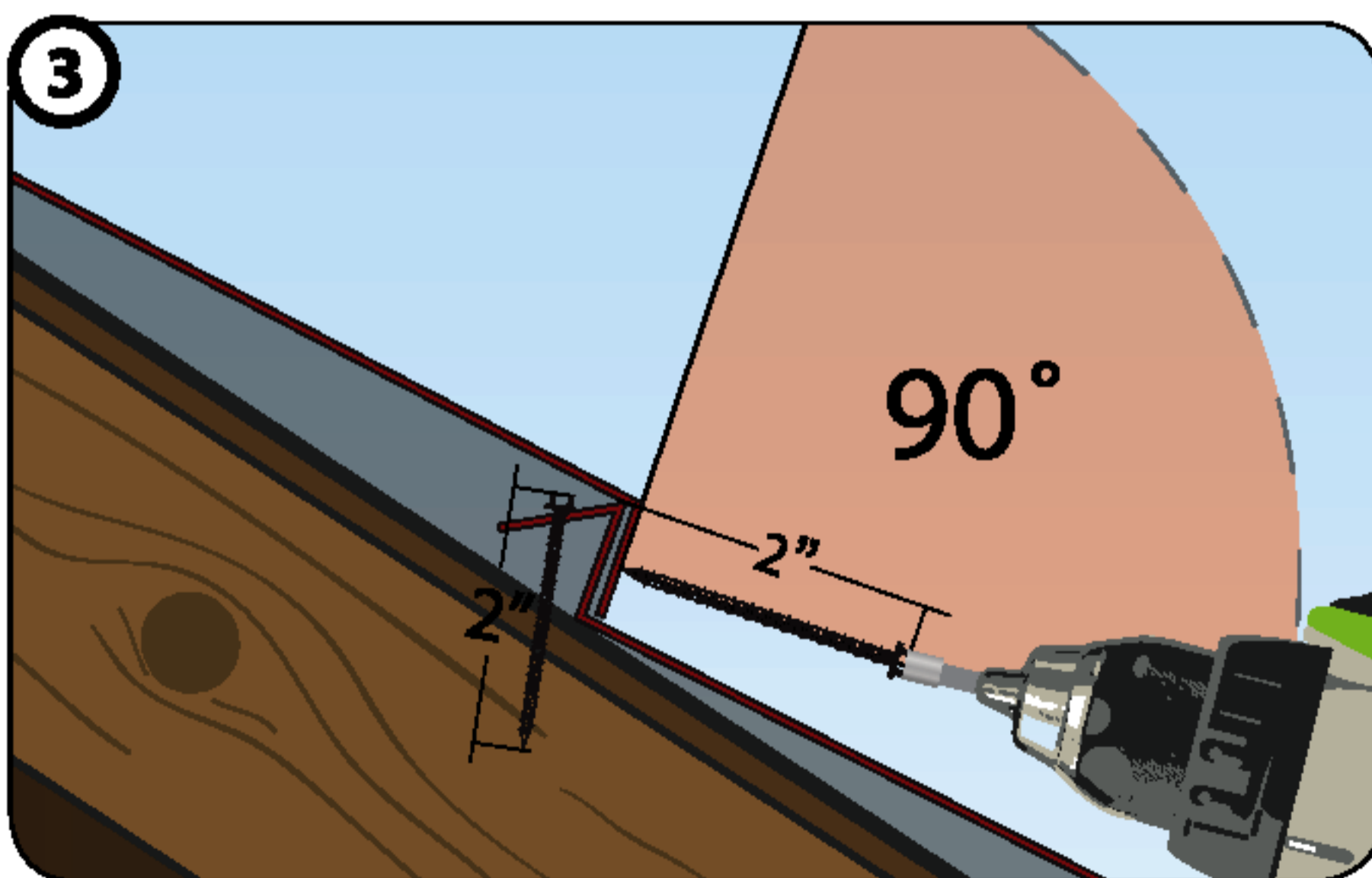

3 Start fastener at a 90° angle to the panel as shown.

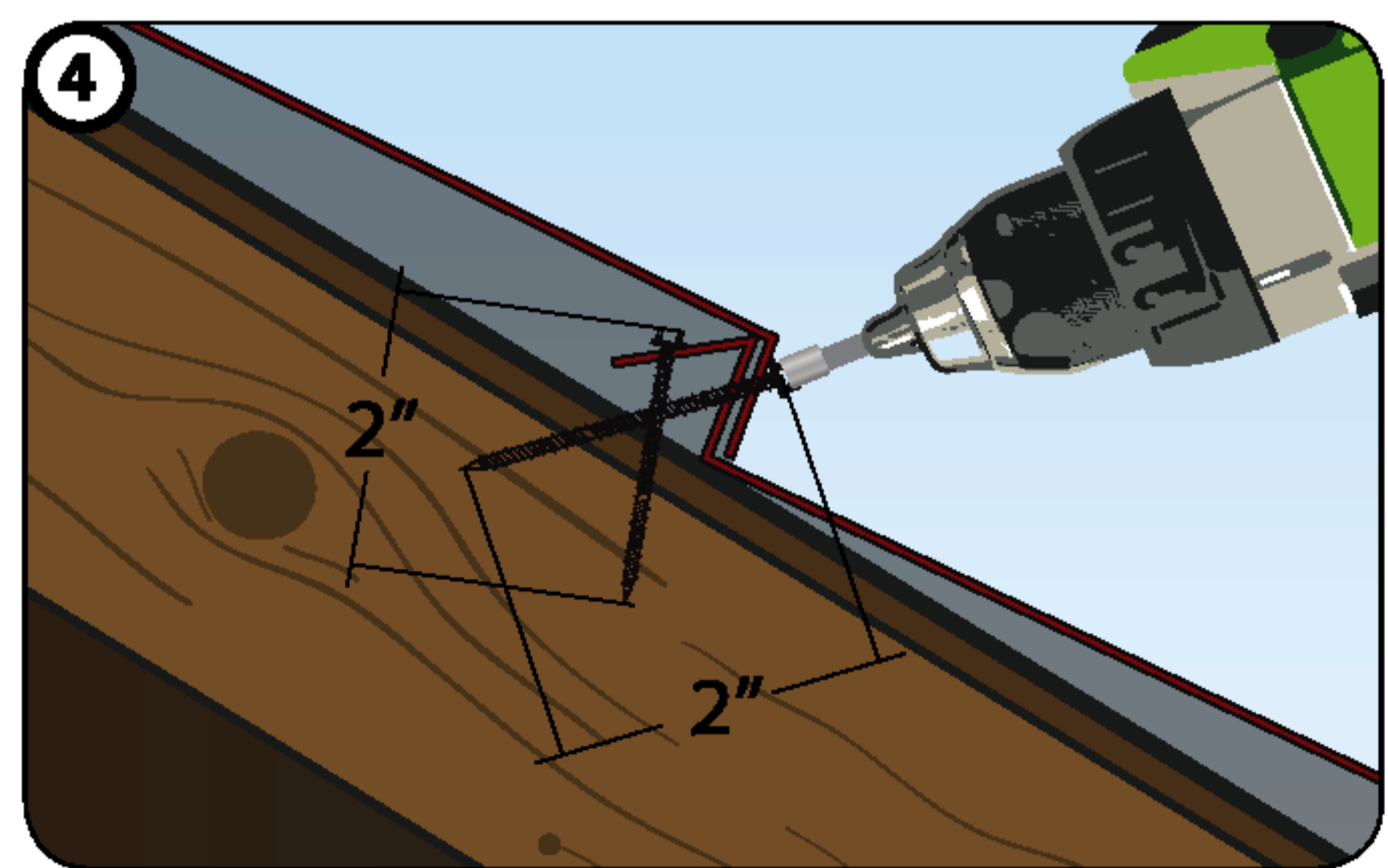

4 Once fastener has penetrated the nose, angle the screw to penetrate the back up-stand of the panel beneath and into the deck.

1ST ROW FASTENING - NAILS OR SCREWS

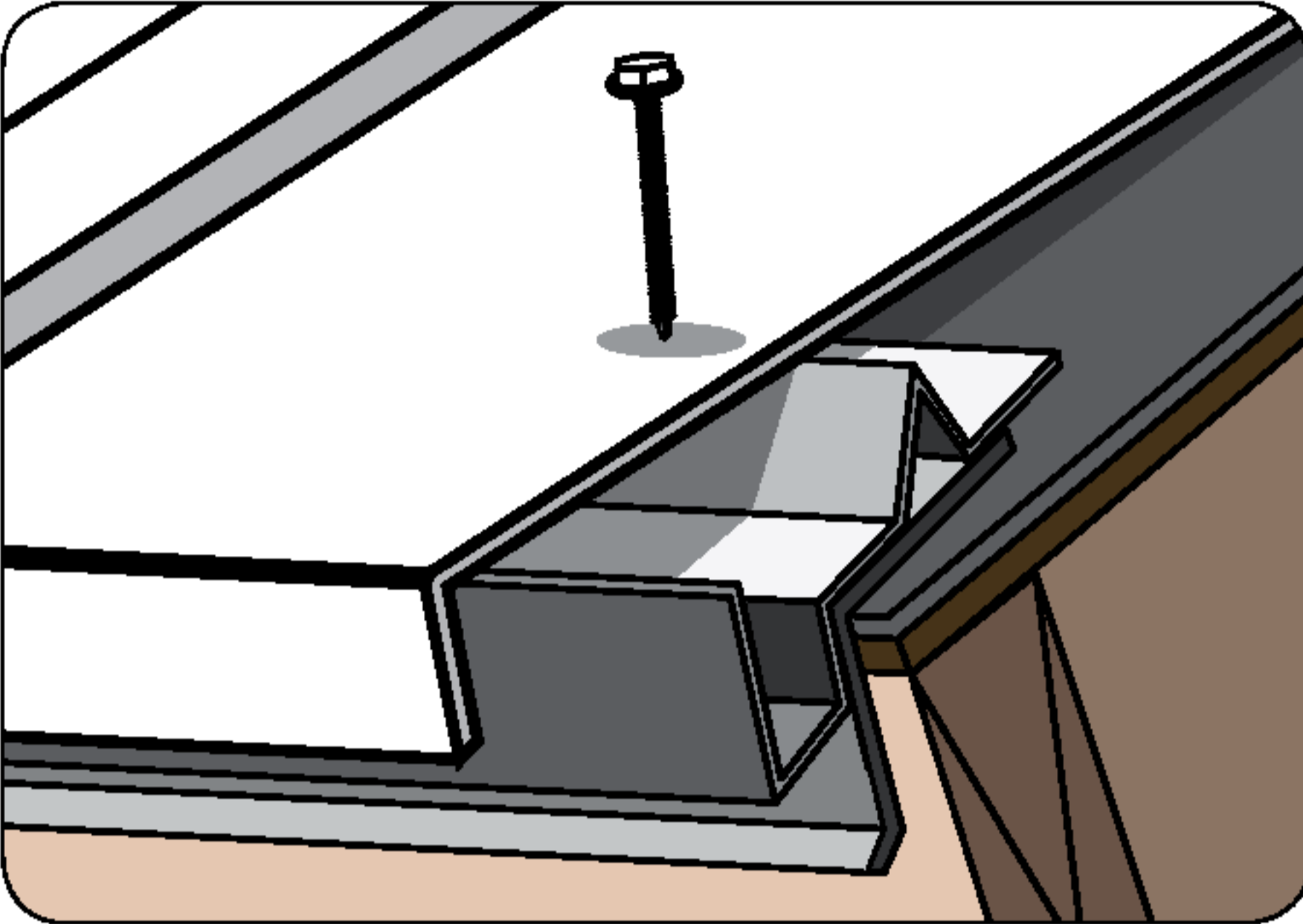

Fasten the First course up from the fascia through the top as shown. Top panel fastening is also acceptable behind Metro SMART-vents and chimney/skylight details as necessary. Use fasteners with self-sealing rubber washers covered by a dome cap or seal fasteners then cover with Metro touch-up kit.



Use the Metro "Touch-up" kit to cover each top nose fastener at the fascia.

RIDGE PANELS

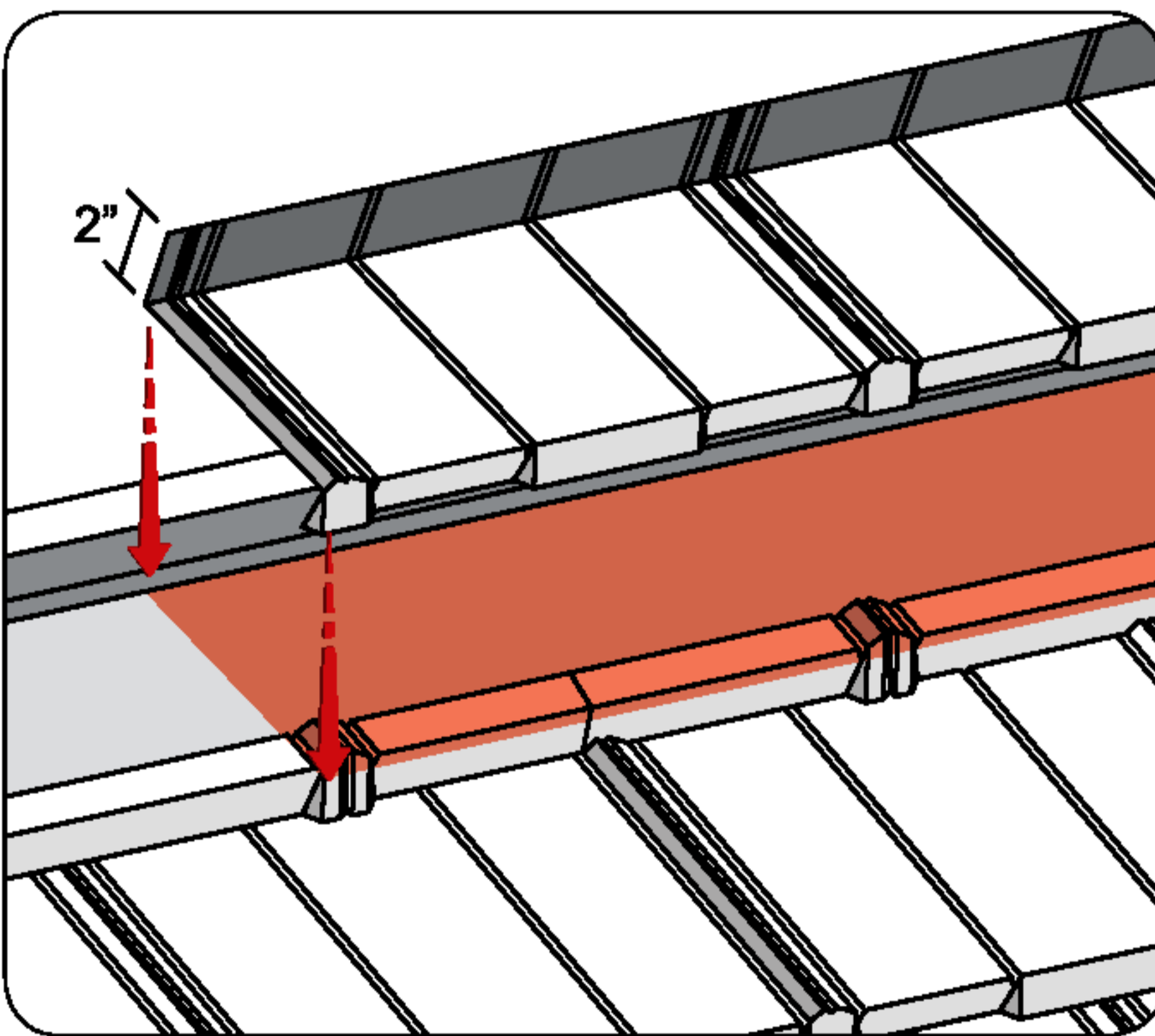

Deduct 1/4" (12mm) from actual measurement to ensure a tight fit.

Measure, cut and fold up panels 2" (50mm) beyond ridge line. Install ridge section panels placing additional fasteners through the up turned flange into ridge board as shown.



Always fold full panels at ridges before cutting off the excess. The cut & bent ridge panels may need to be bowed in the center after pinning each end of the panel as you install them.

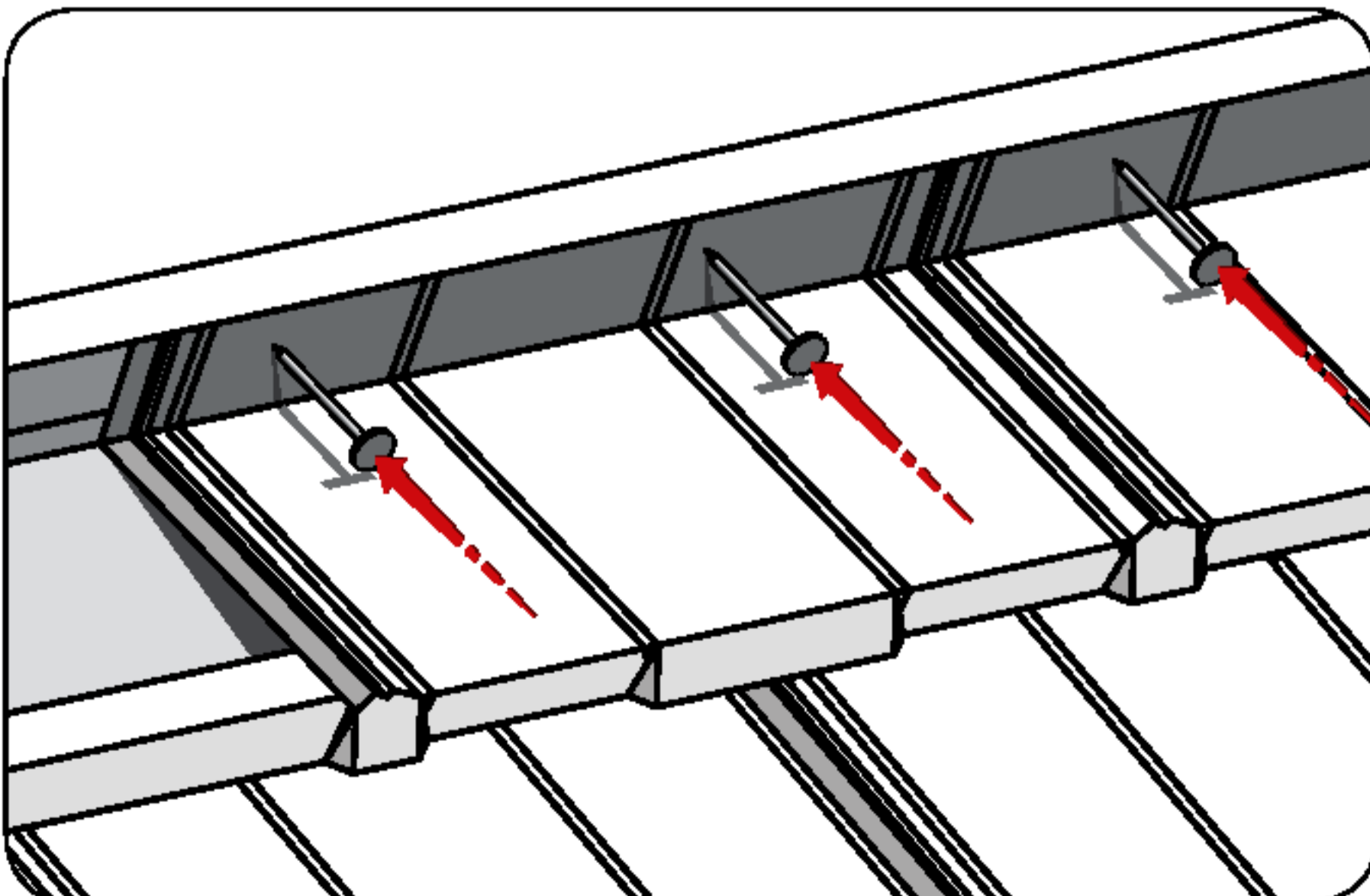

HIP PANELS

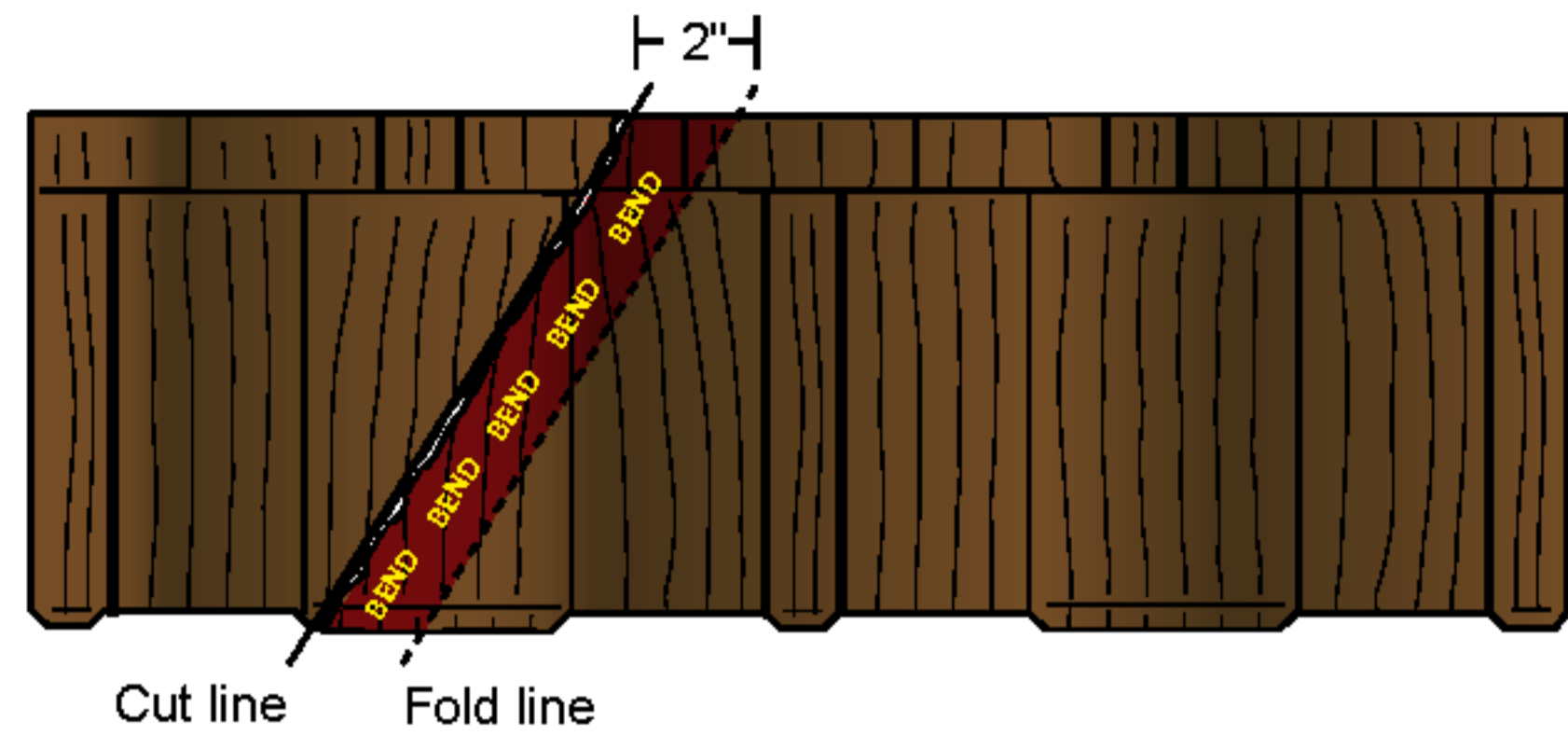
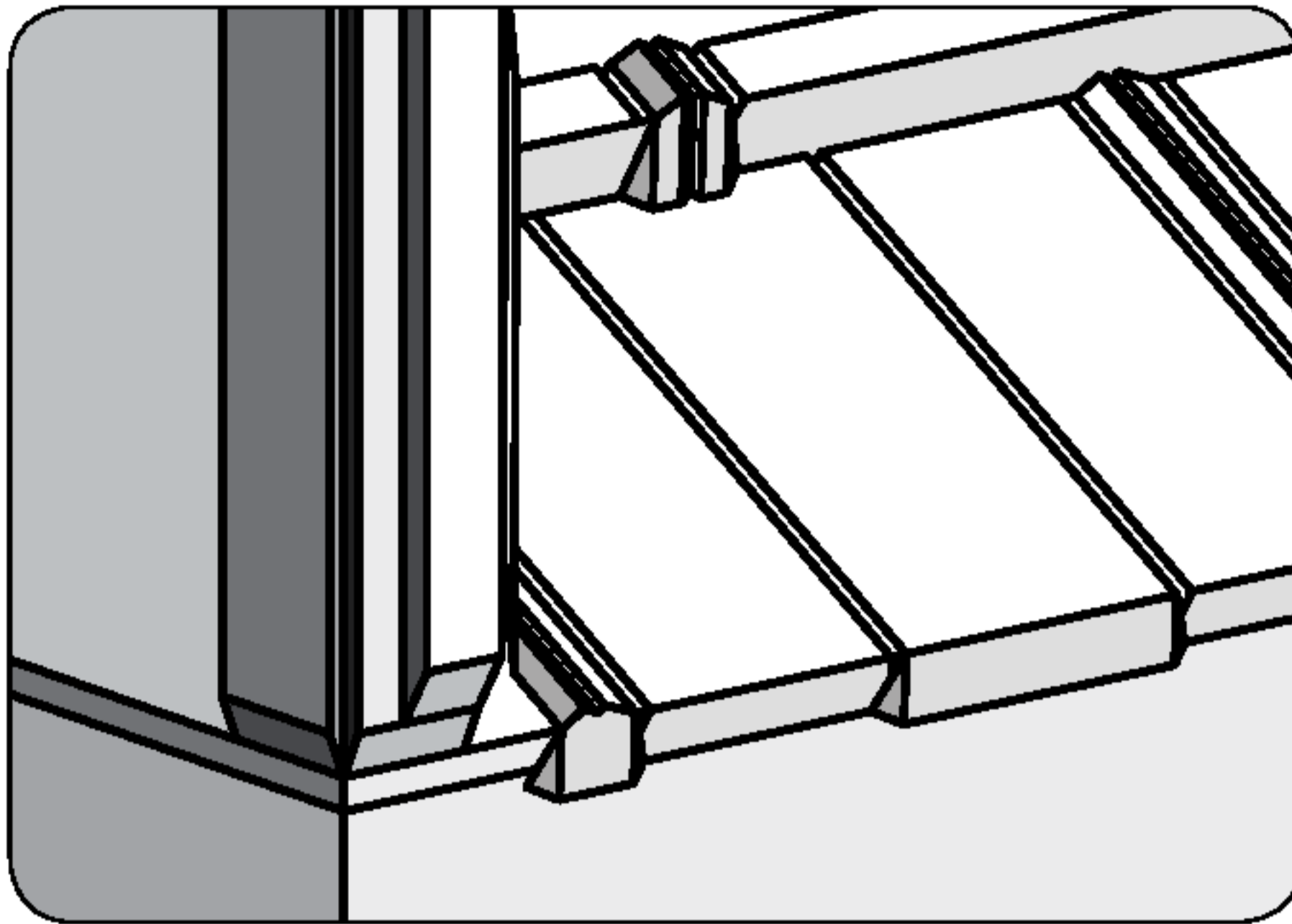

Measure, cut and fold up panels 2" (50mm) at the hip line. Install hip section panels similar to other panels placing additional fasteners through the up turned flanges as shown into hip board.



At hips, use either a full panel or a cut section long enough to obtain the hip cut.



Always deduct 1/2" (12mm) from your measurements for Hip & Ridge cuts to ensure they fit easily.

VALLEY CUTS

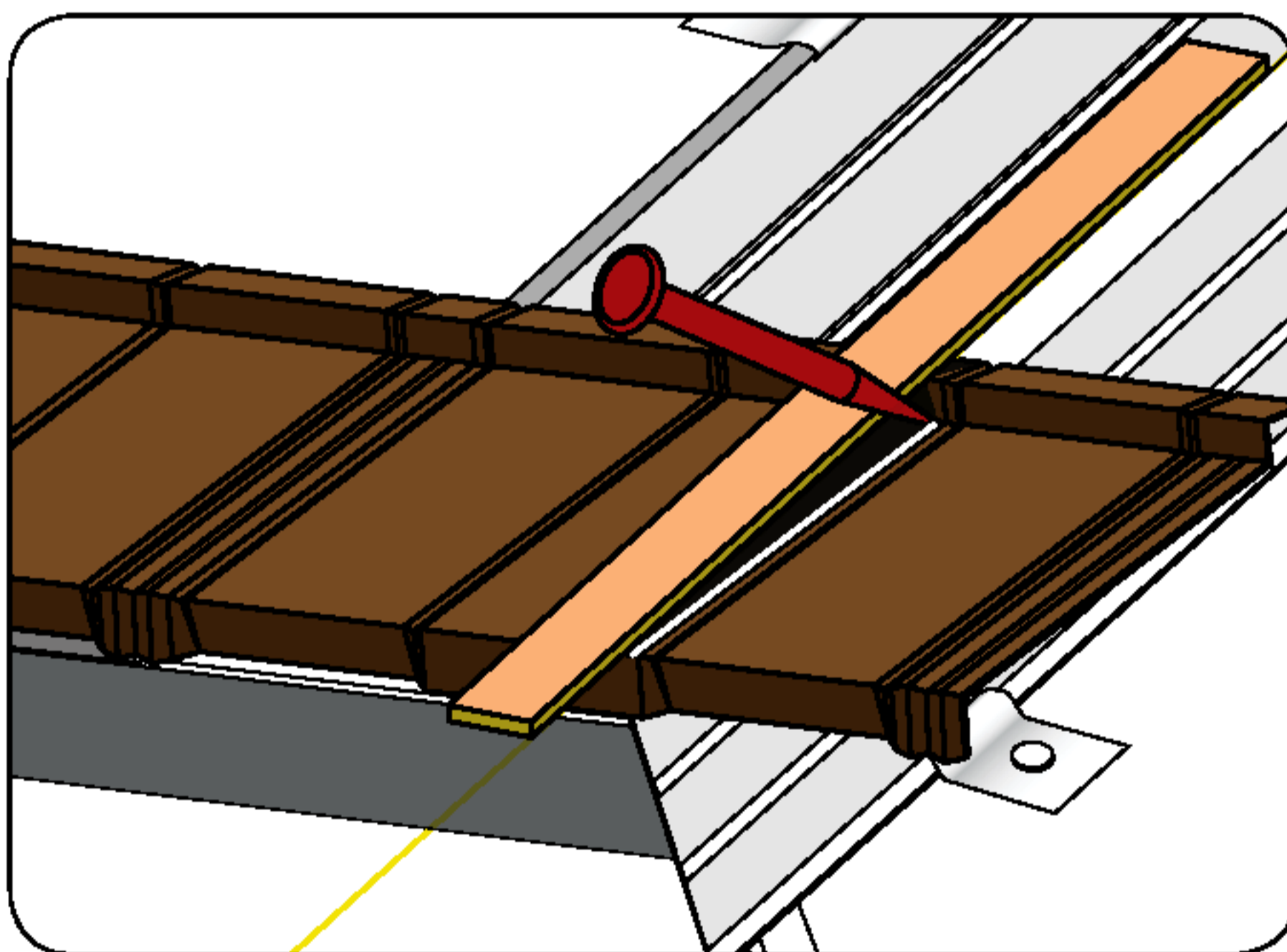

Measure, mark & cut panels to fit tightly against valley center (reverse 'V'). Fasten valley section panels to roof decking similar to the other panels without penetrating valley flashing.

Stitch panels together that lap over valley metal with corrosion resistant screws (#8 x 1/2" long (12.7mm)) making sure to not penetrate valley flashing.

Valley cut sections can be turned down 3/4" (20mm) into valley pan, for extra rigidity.

Install a Metro Valley Cover metal down the center of the valley lapping each section a minimum of 4" (100mm). The valley cover is fastened to each panel course where it intersects the valley.

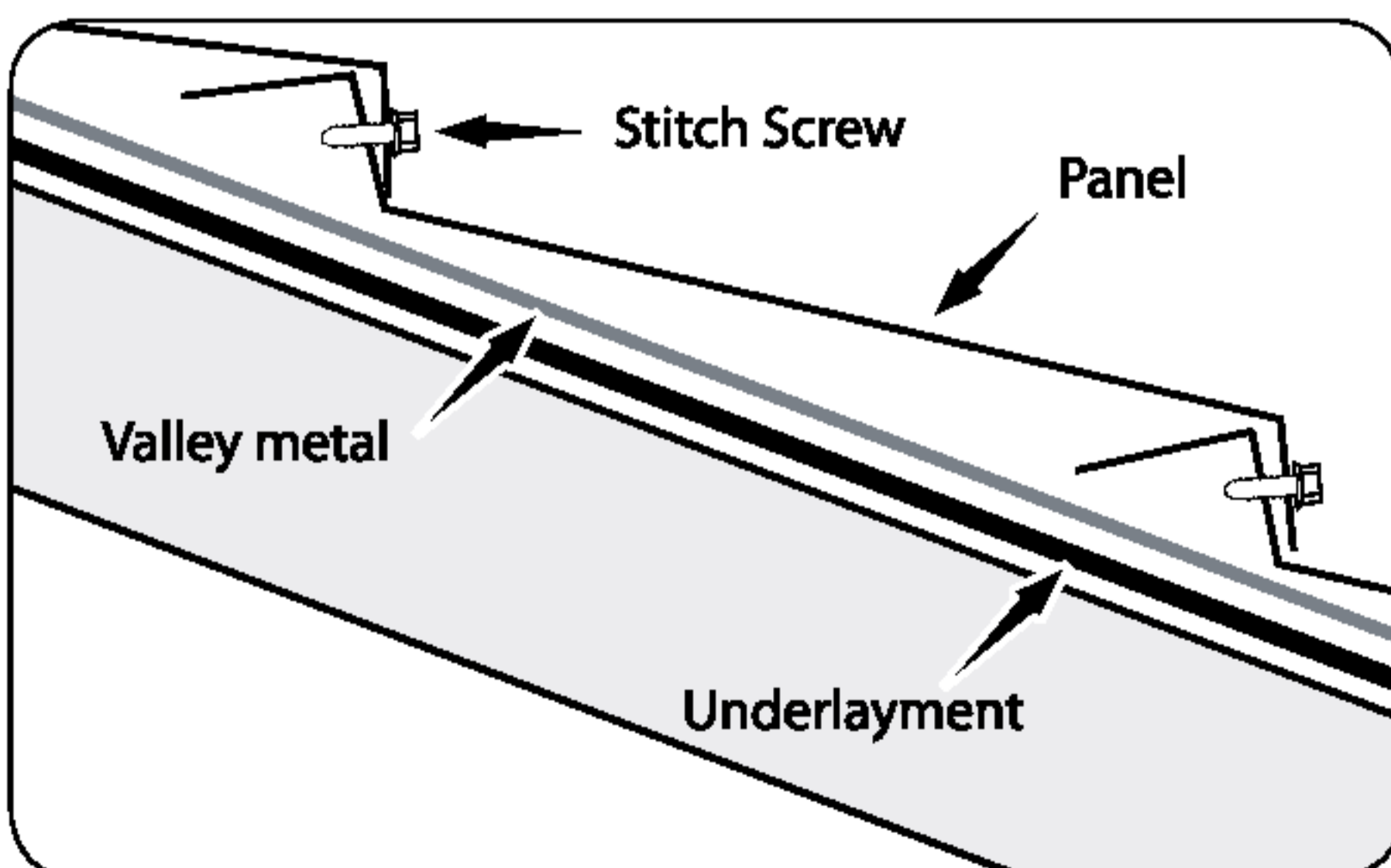

WARNING symbol ! Make sure you do not penetrate the valley metal, use small Stitch screws to secure the valley cover.



Start the 1st panel 12" (300mm) from the Valley edge. This allows for a valley cut section that can be securely fastened to the roof deck without penetrating the valley pan.



CLOSED VALLEY

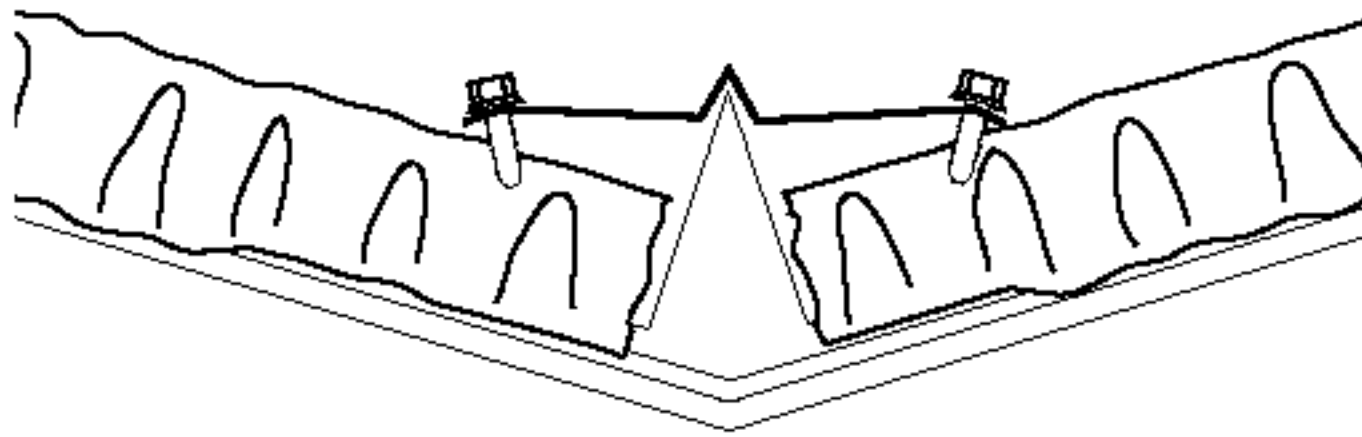

Install a Metro Valley Cover metal down the center of the valley lapping each section a minimum of 4" (100mm). The valley cover is fastened to each panel course where it intersects the valley.



Make sure you do not penetrate the valley metal, use small Stitch screws to secure the valley cover



OPEN valleys (min-6-inches) between each side of the Metro panels are recommended for areas where trees or other debris may block the valley. This detail facilitates easier periodic cleaning of the valley pans.



Use stitch screws or short fasteners to prevent penetration of the valley pan.

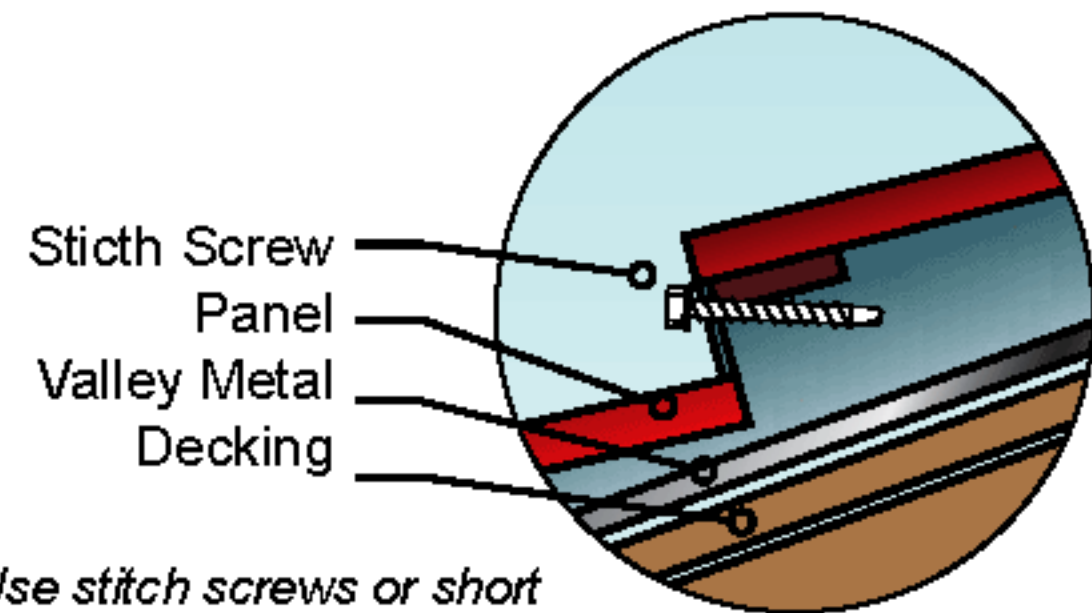

3-IN-1 SMART-JACK

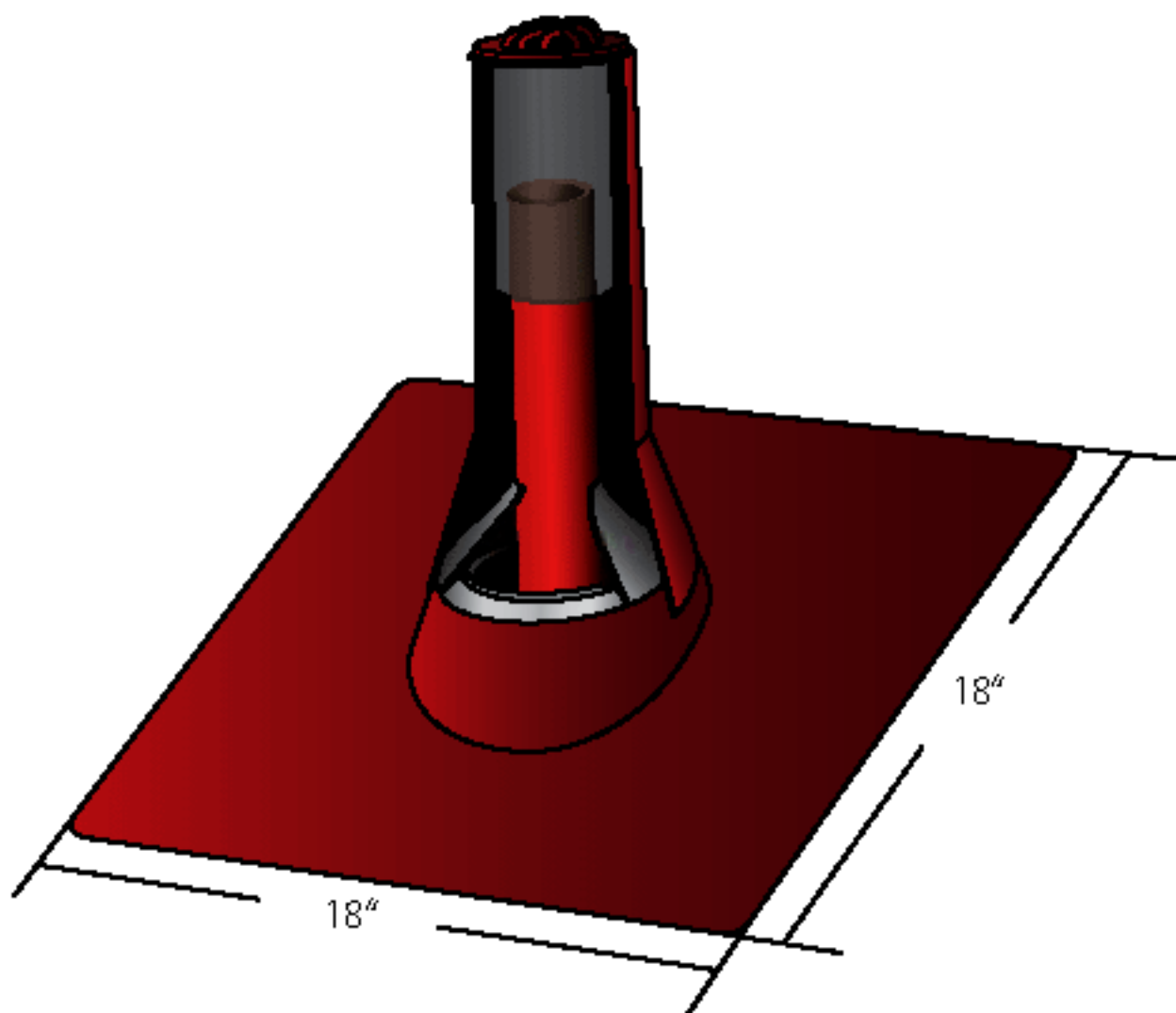

The Metro 3-in-1 SMART-jack is a moldable stone-coated roof flashing that can be used on most roof vent pipes, 1" to 3" in. dia. Apply sealant under 3-in-1 SMART-jack to keep it secured to panel beneath.



If a vent location prevents SMART-jack 3-in-1 from being able to fold up and over the panels back flange, the Metro 'Sandwich' method should be used

SMART-JACK PREPARATION

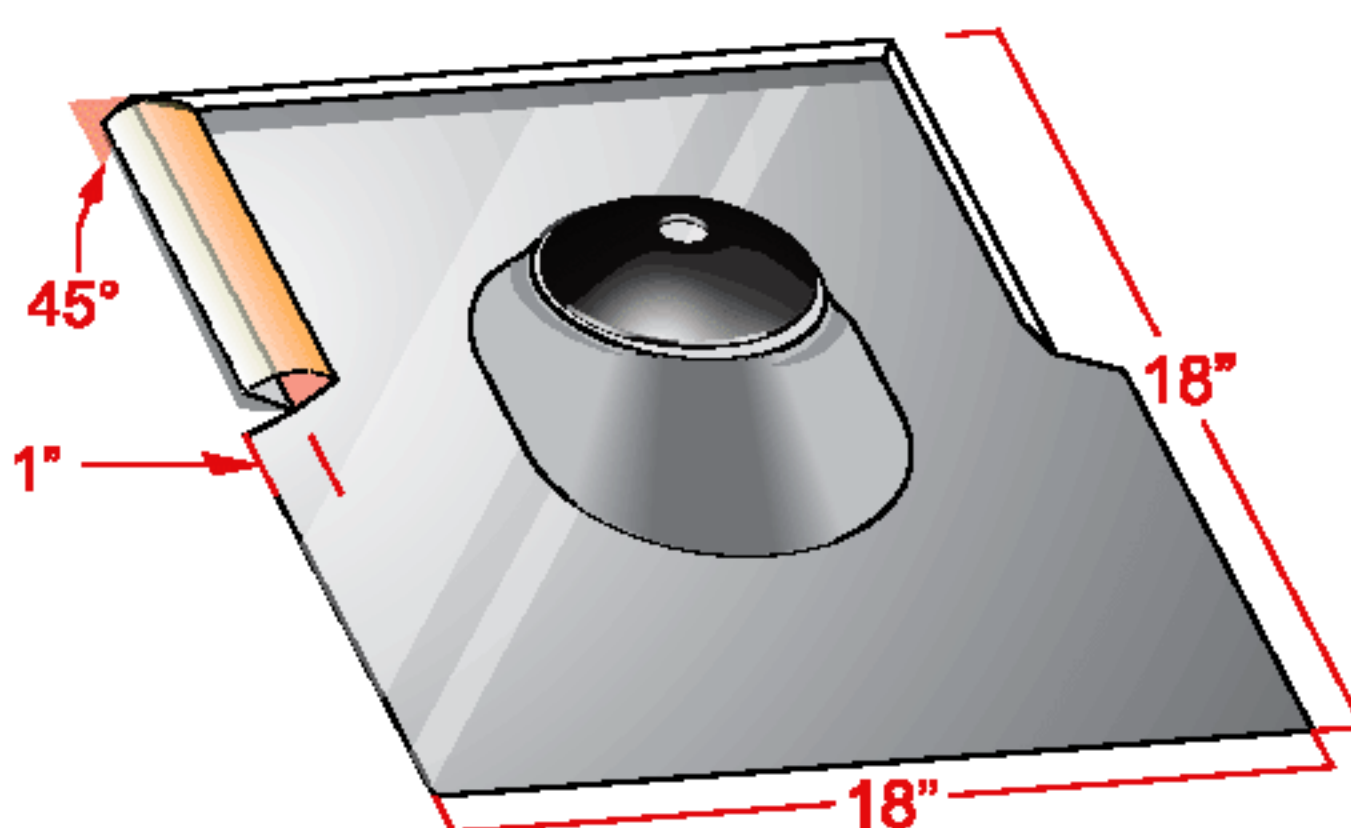

To maintain good weather protection the edges of the SMART-Jack flashing should be folded/bent up as shown to deflect any moisture onto the flashing and out onto the panel below.



PIPE FLASHING - SMART-JACK & SMART-SLEEVE METHOD

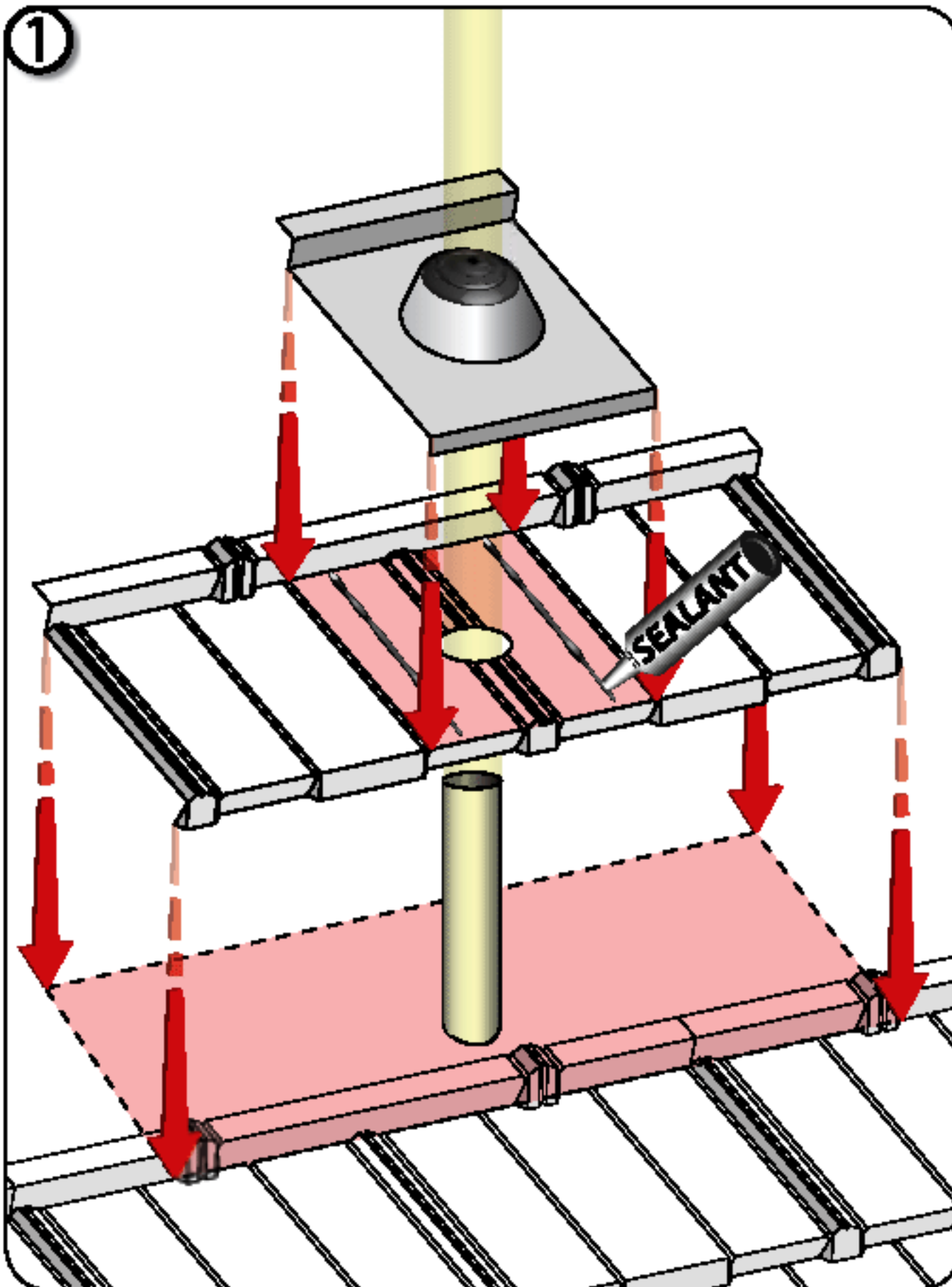

1 Cut a pipe sized hole in the covering panel as shown. Install covering panel and apply a bead of sealant on each side and around the hole of the pipe as shown. Slide the SMART-Jack flashing over the pipe and seat it into the sealant and conform the SMART-Jack Flashing to the panel contours.

Universal single size for most pipes on a roof; 1-4 (Fit pipes 1" - 4" (25-100mm) in dia.)

Dissimilar Metals



To avoid adverse corrosion effects caused by dissimilar metals, COPPER and LEAD flashings should not be used with Metro roof products and accessories

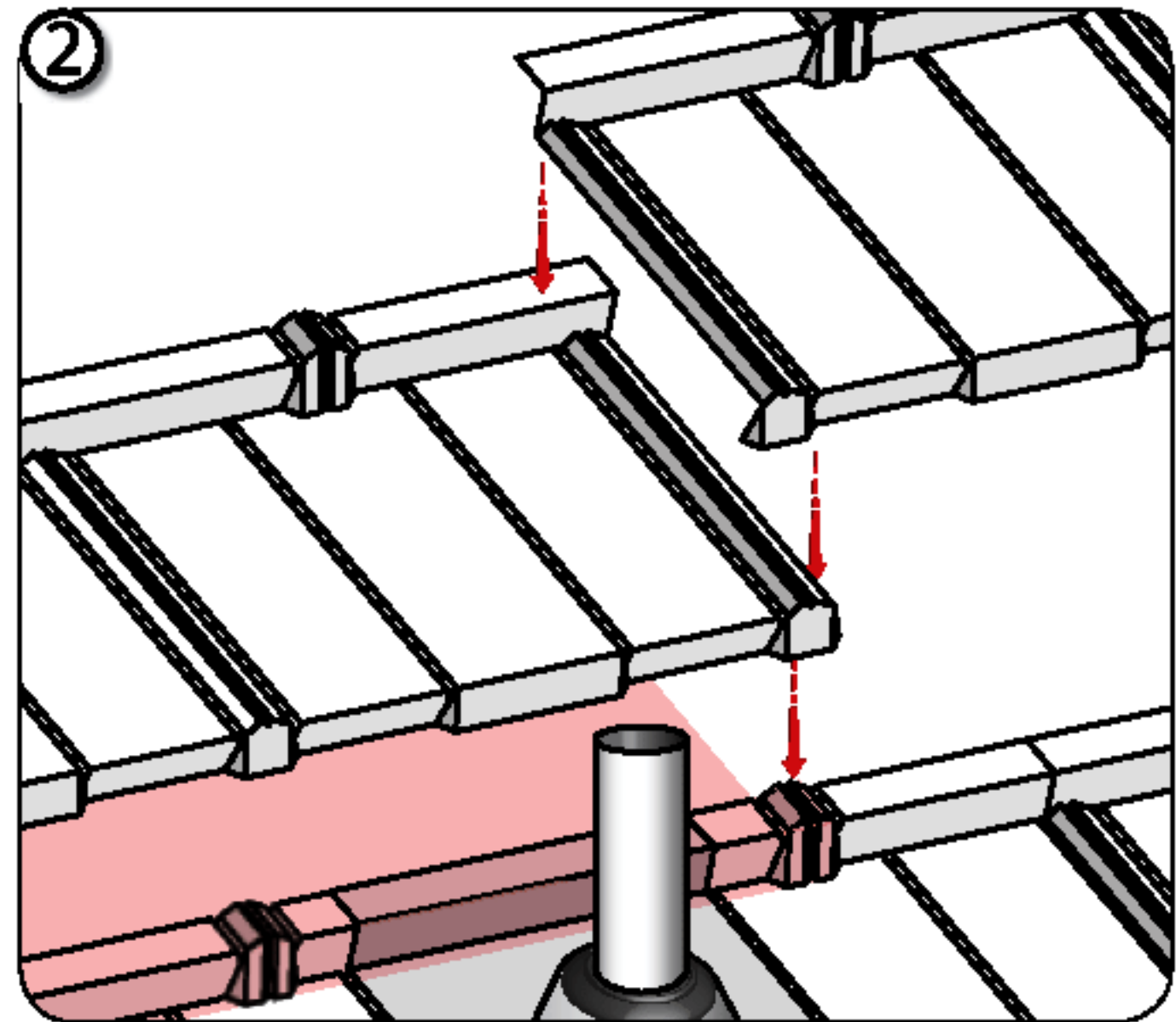

2 Install subsequent course above the SMART-jack flashing.

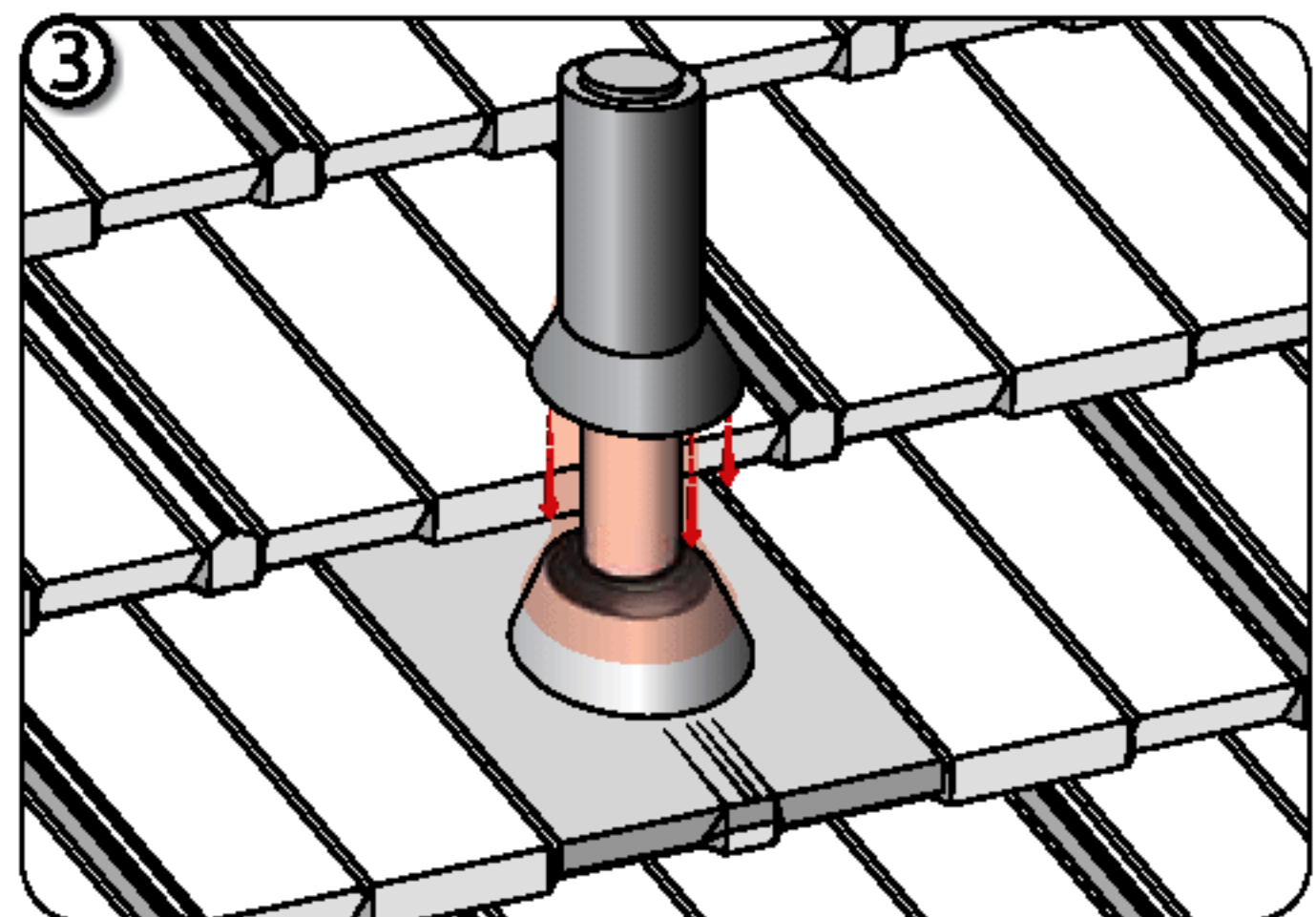

3 For added protection and appearance, SMART-sleeves are cut to conform to the panels and are installed over pipes. SMART-sleeves are fastened with a screw through the back of the SMART-sleeve into the pipe.



PIPE FLASHING - UNDERPAN SANDWICH METHOD - SMART-JACK

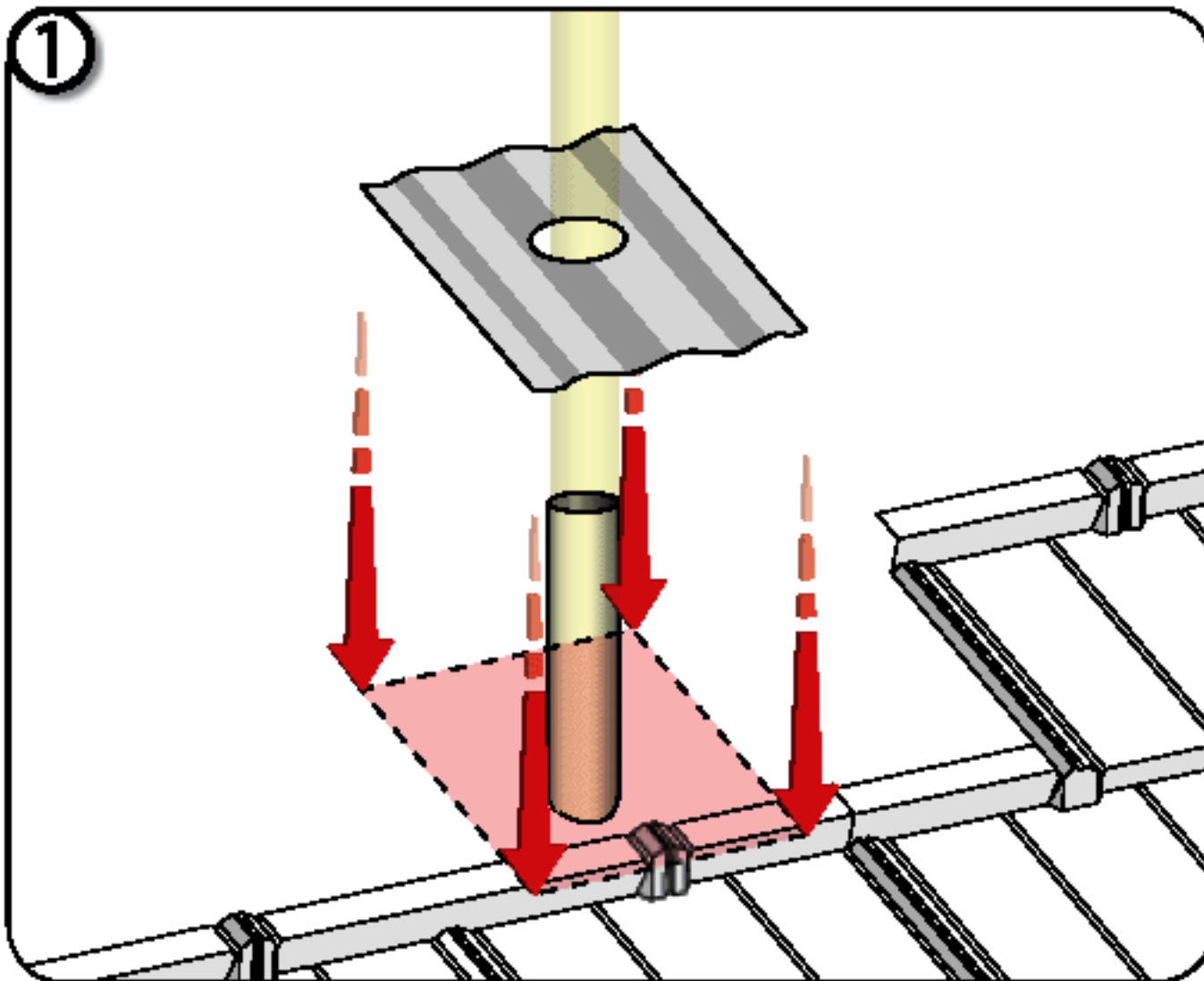

1 Cut 'Under-Pan' flashing around Vent Pipe as shown. Bend front edge of 'Under-Pan' over rear of under lapping panel.

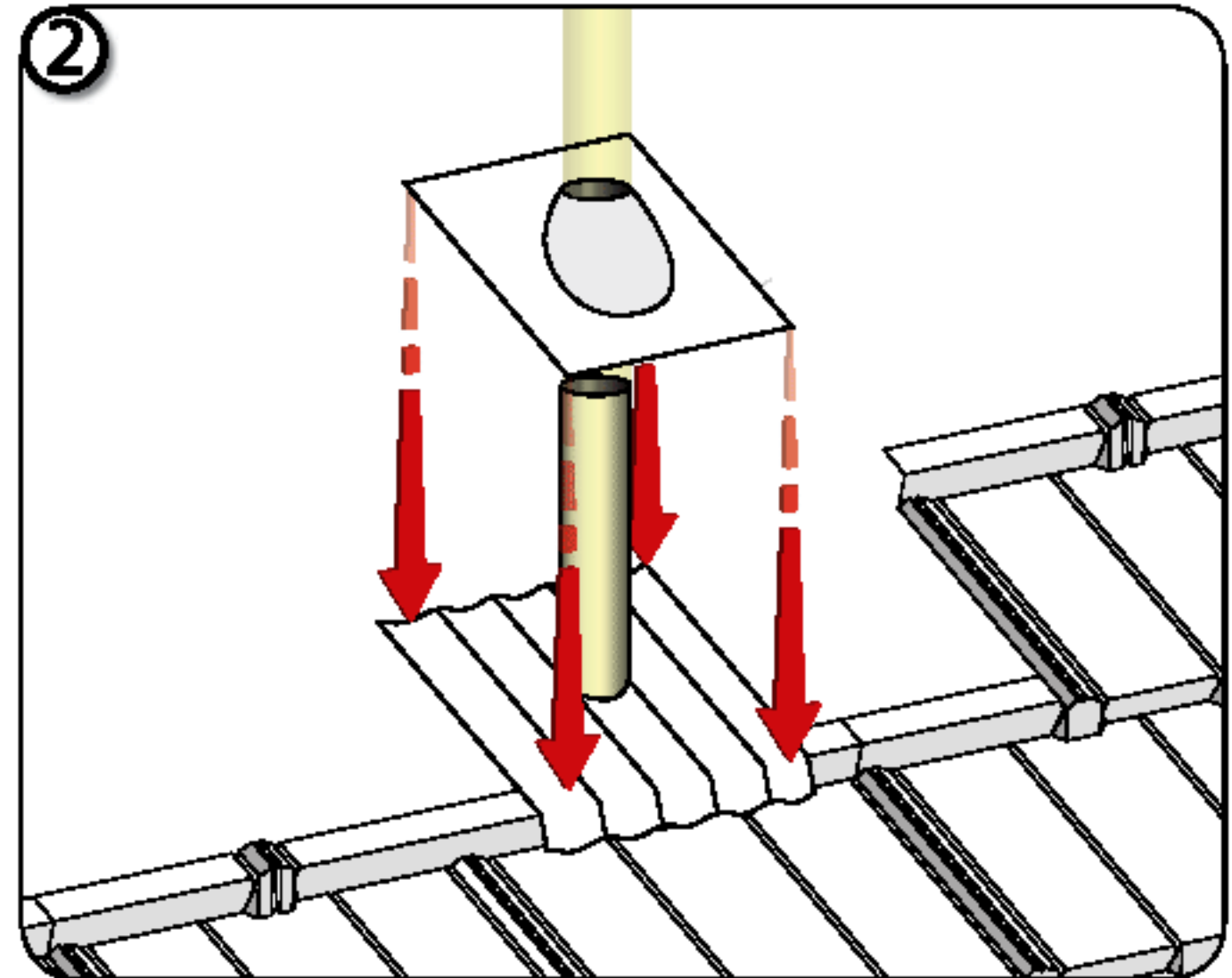

2 Install pipe flashing over 'Under-Pan'.

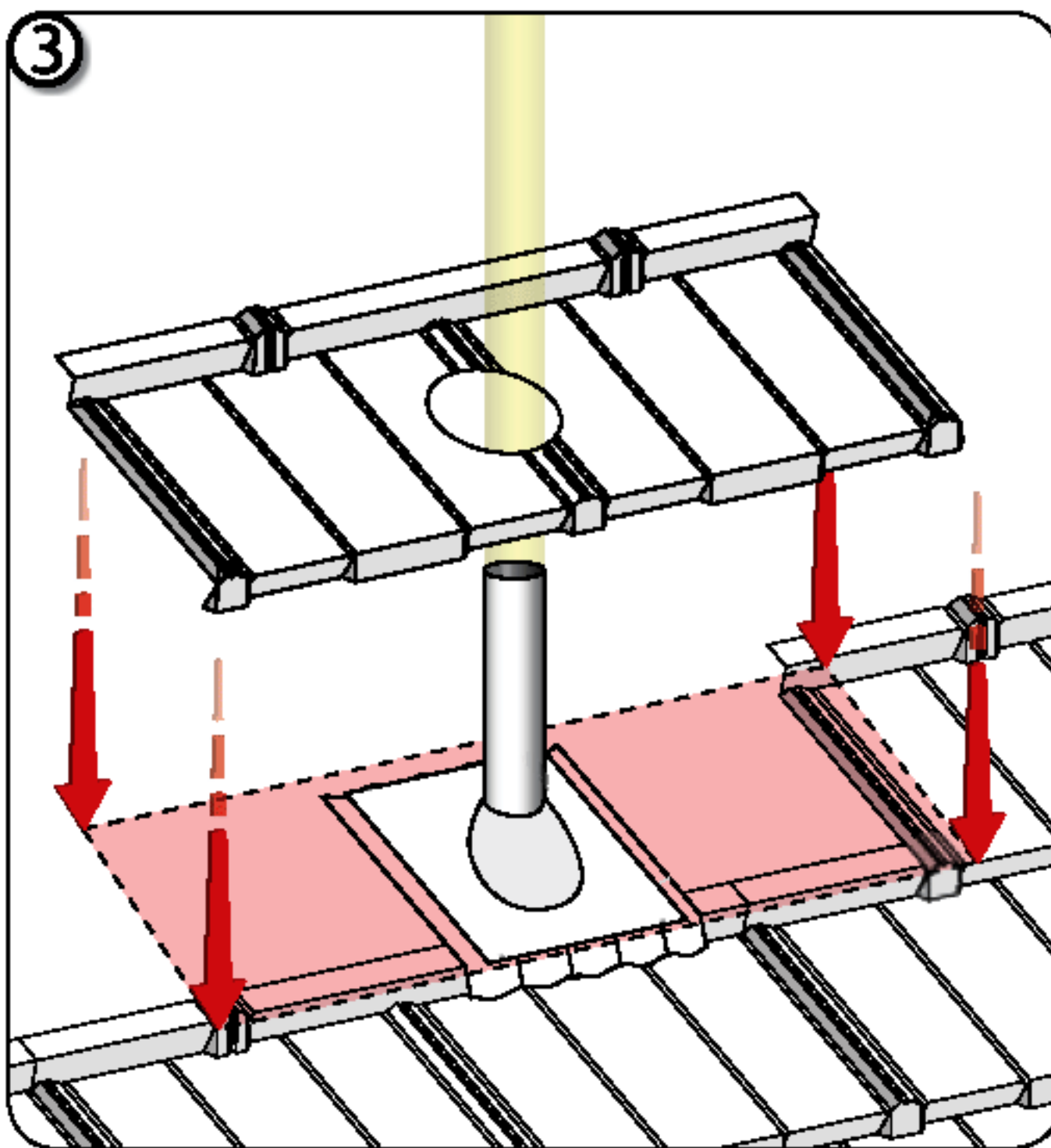

3 Cut a hole in the covering panel to fit the cone of the Pipe Flashing.

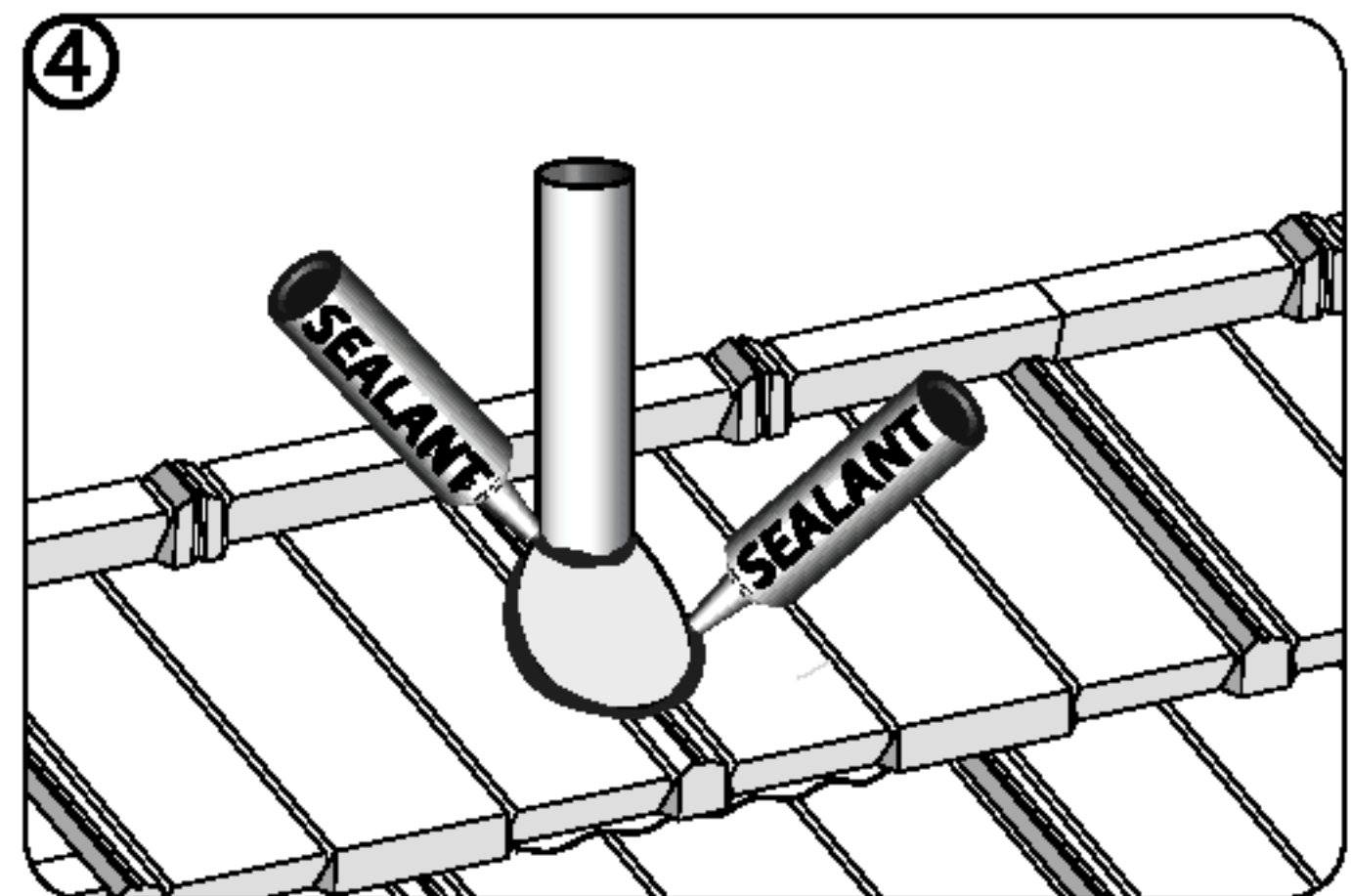

4 Seal Vent Pipe around bottom of cone and around pipe flashing as shown.

Dissimilar Metals



To avoid adverse corrosion effects caused by dissimilar metals, COPPER and LEAD flashings should not be used with Metro roof products and accessories

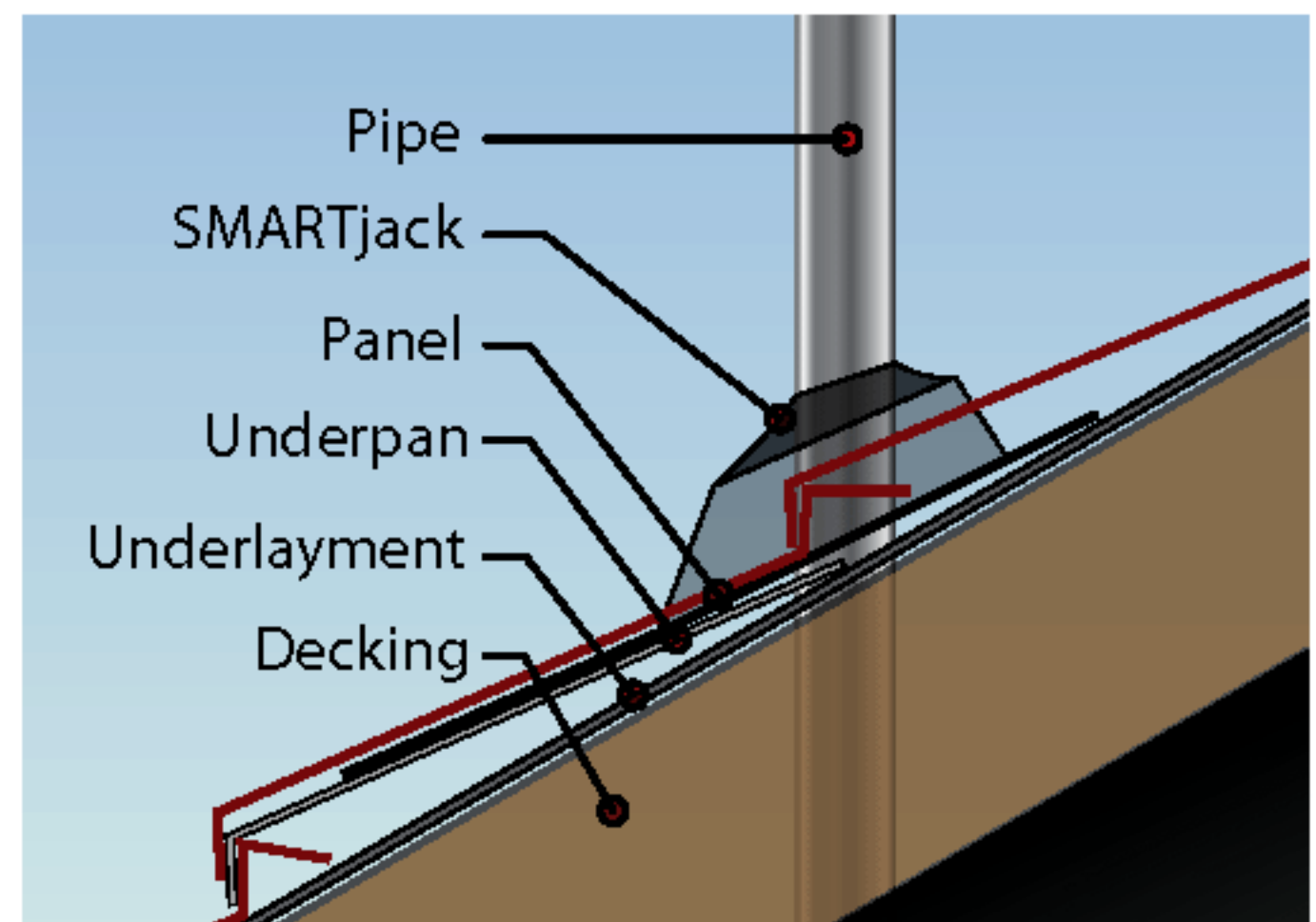

SMART-VENT - BATTEN-LESS SHAKE-II

Metro SMART-vents are used in place of regular panels on the first full course down from the ridge where ventilation is required. The vents are installed similar to panels after cutting ventilation hole in decking (approximately 8" x 30"). A Metro SMART-vent provides approximately 82 sq. inches of Net Free Vent Area (NFVA). Care should be taken to adequately ventilate the building. Building codes require a minimum NFVA of 1/300 the area of the space to be ventilated (attic).

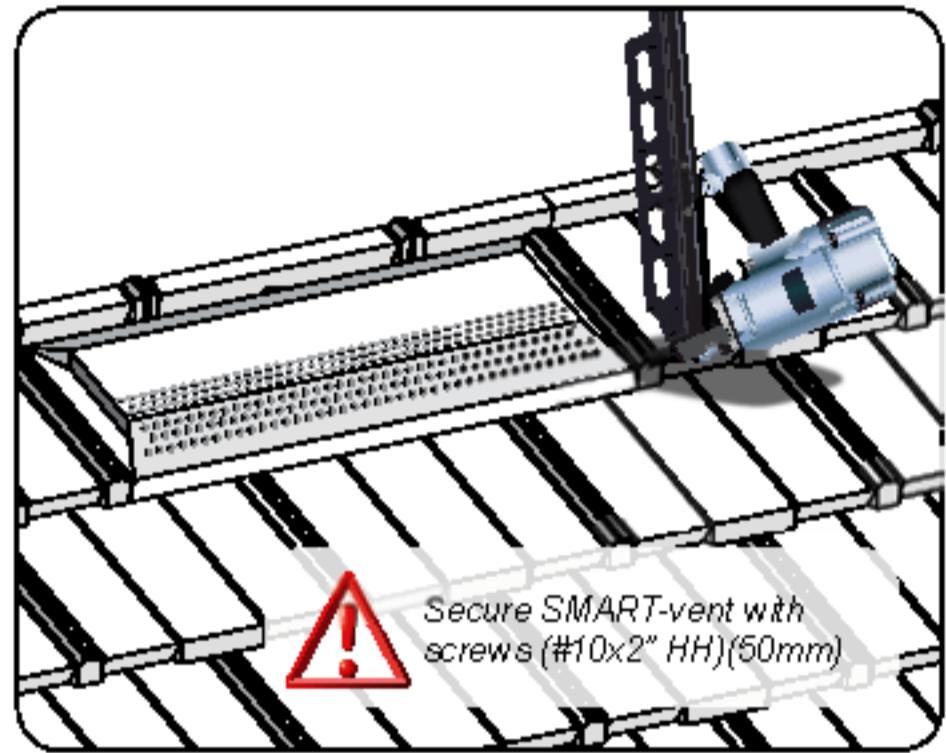
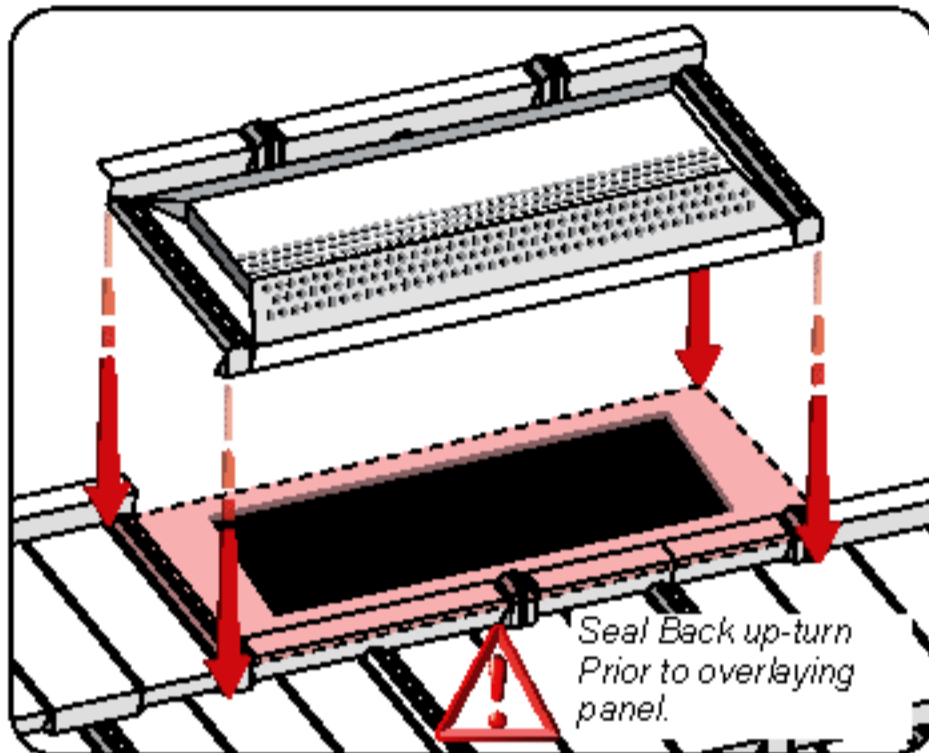

Always check local codes and ensure you have adequate intake ventilation for the quantity of exhaust SMART-vents you are installing.

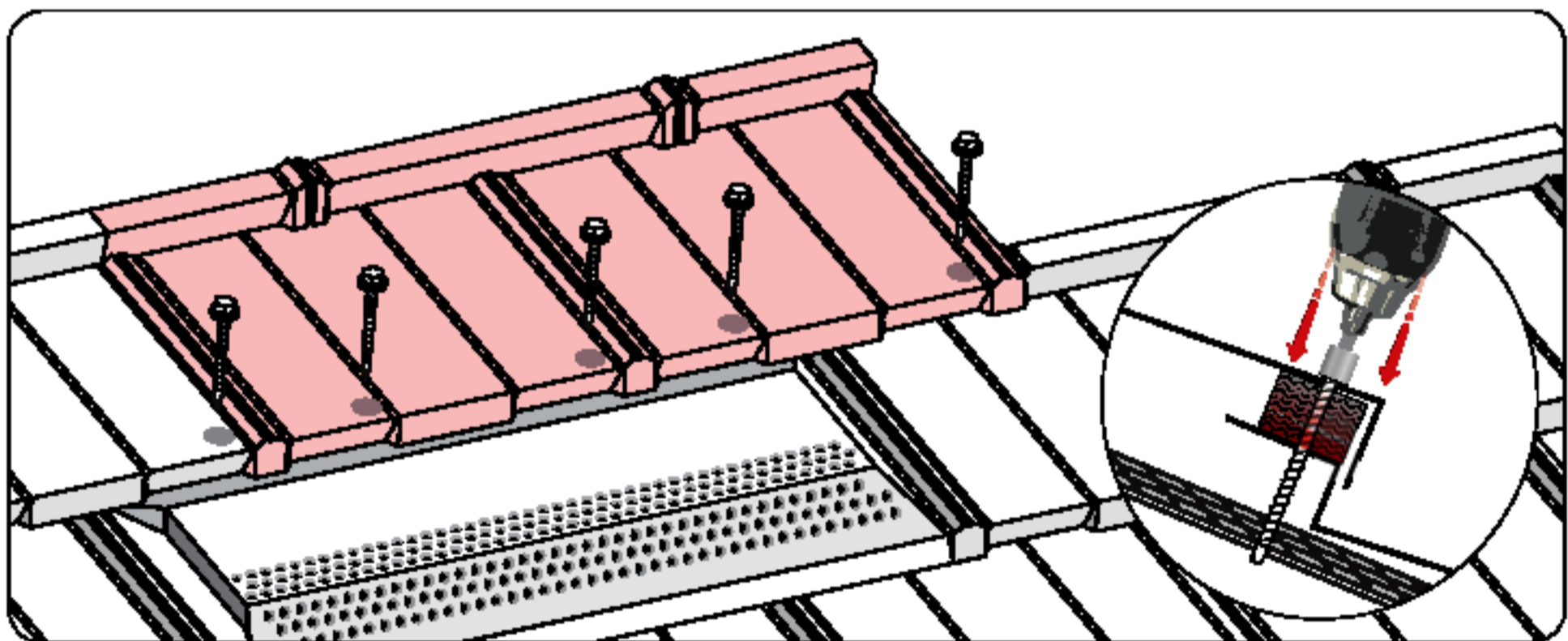

Top panel fastening is acceptable behind Metro SMART-Vents, Chimney's & Skylights as shown. Use fasteners with self-sealing rubber washers covered by a dome cap or seal fasteners then cover with Metro touch-up kit.

CHIMNEY SADDLE PREPERATION

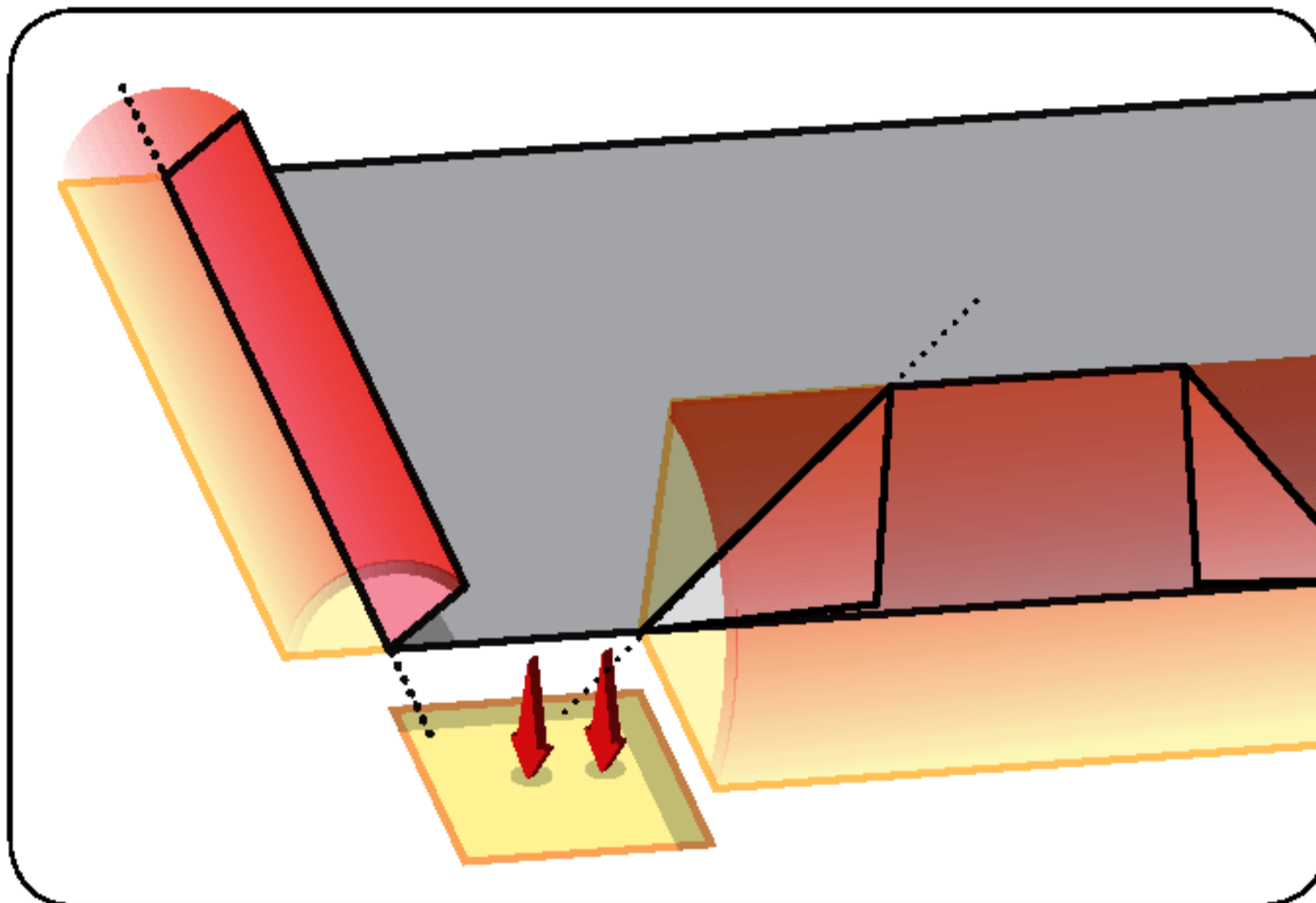

On the sides of the Chimney Saddle create side-hems to deflect water down the sides of the chimney.

CHIMNEY FLAT-STOCK PREPARATION

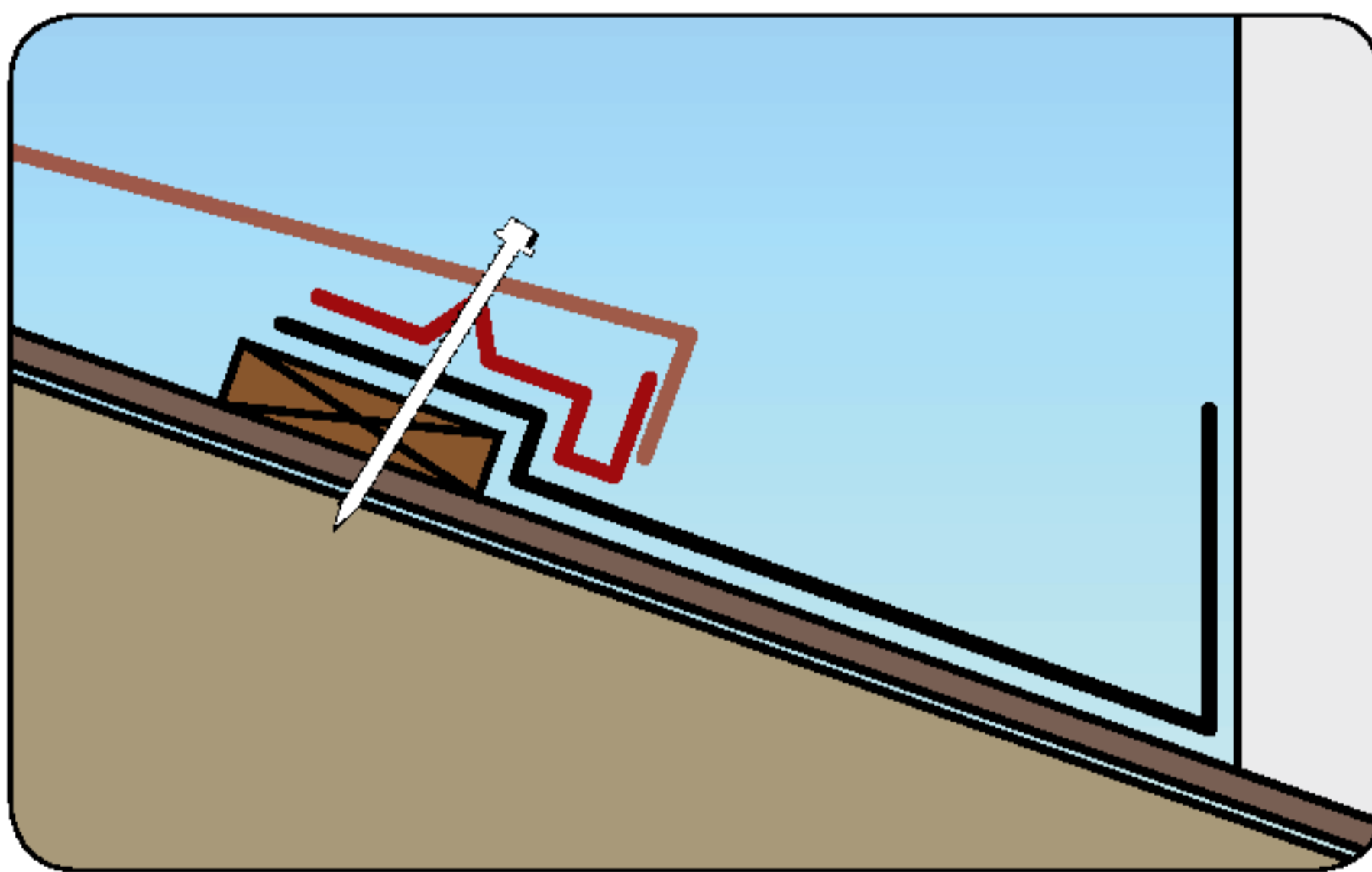

Use a V-Bat Riser Metal piece as shown to elevate the panel to the correct roof plane height. Fasten as shown with the panel nose being fastened into the V-Bat Riser.

CHIMNEY FLAT-STOCK W/ FOAM CLOSURE

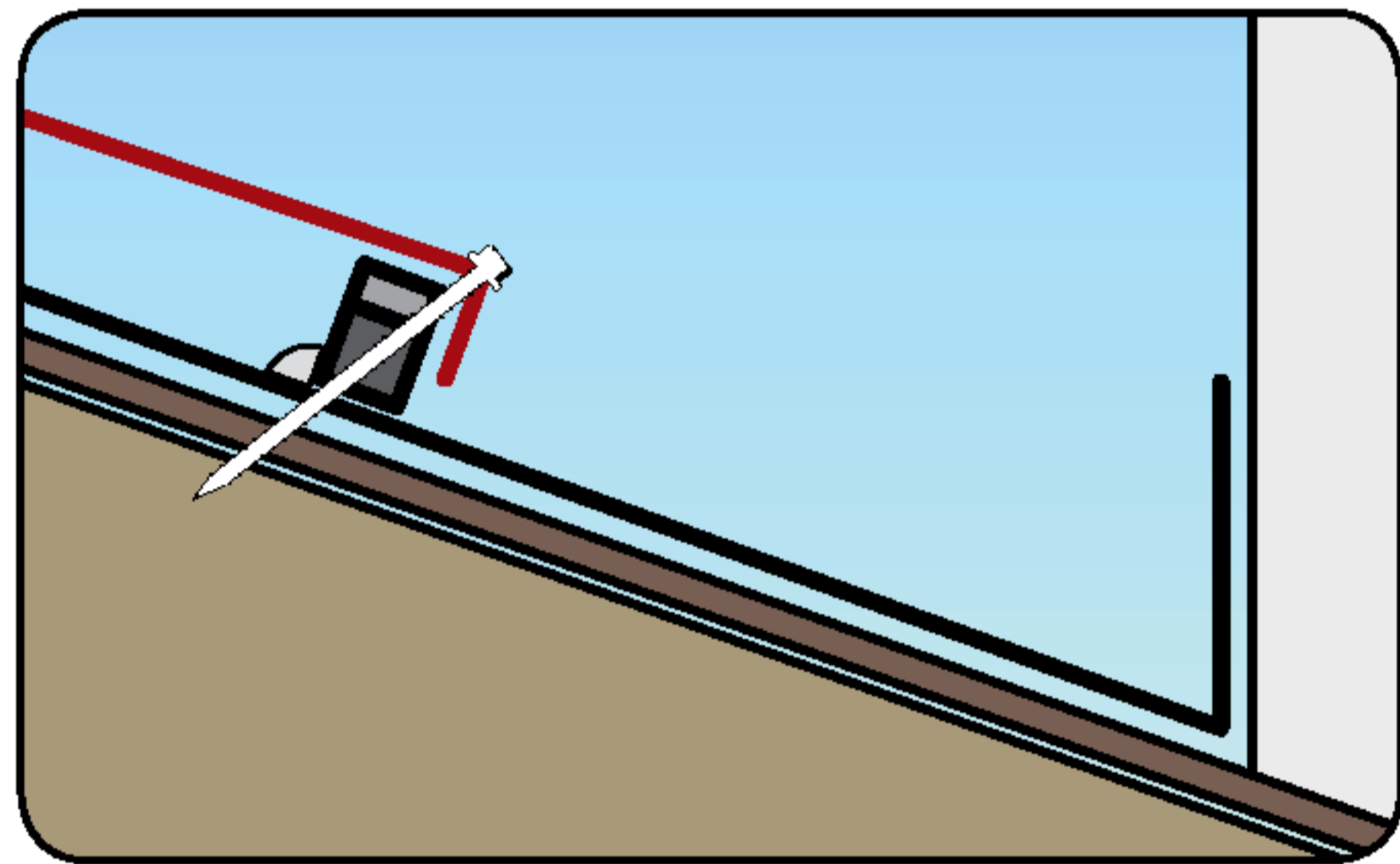

Position the Foam strip in a bead of sealant and fasten as shown. Use Metro Touch-up kit to seal top fasteners.



CHIMNEY / SIDE-WALL / HEADWALL

The following details apply to any square cornered protrusion through roof.

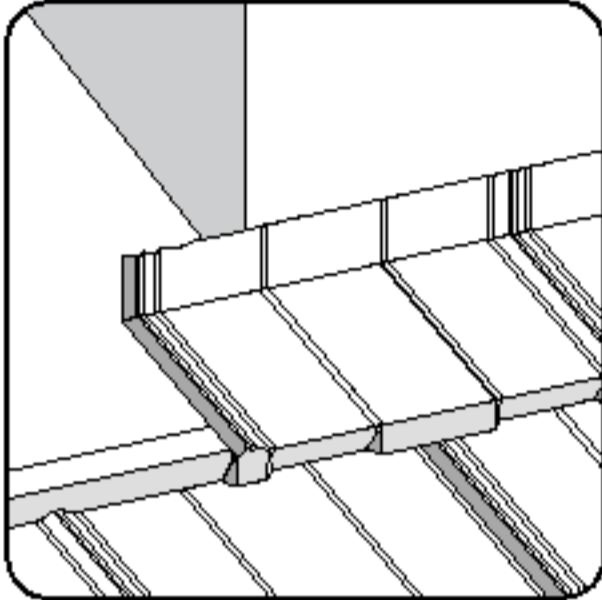

Measure, cut, and fold up panel 2" from the back of the panel to the front of protrusion.

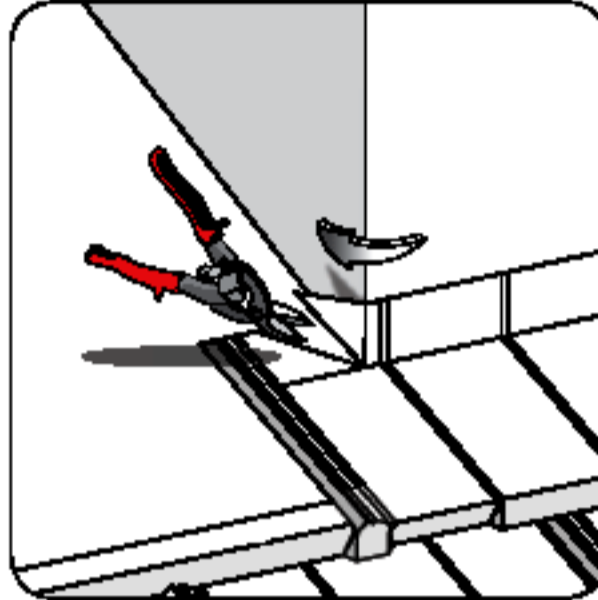

Cut a 45 degree angle as shown and fold tabs around protrusion.

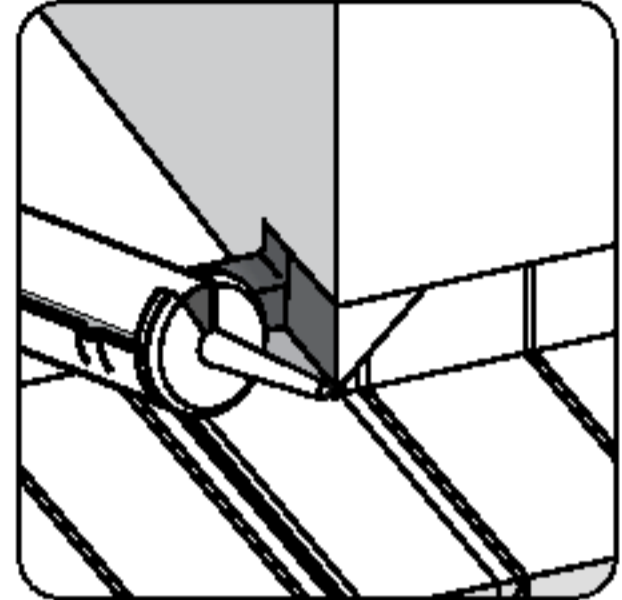

Cut and fold up panels 2" at sides of protrusion as shown.

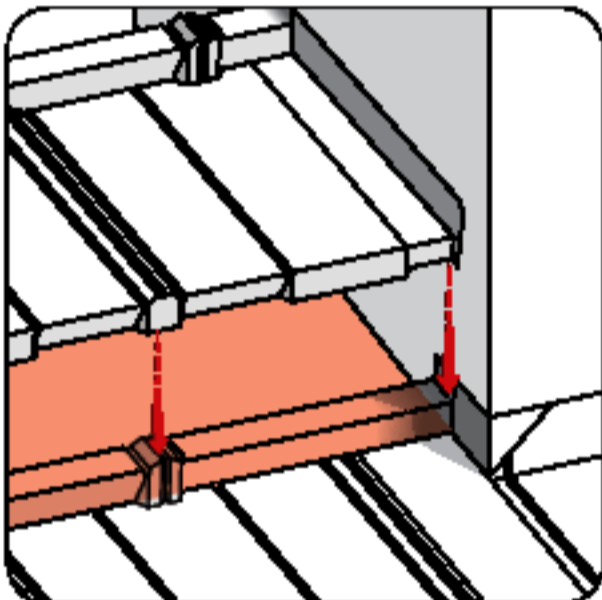

Install subsequent panels with a 2" bend up nested against the protrusion.

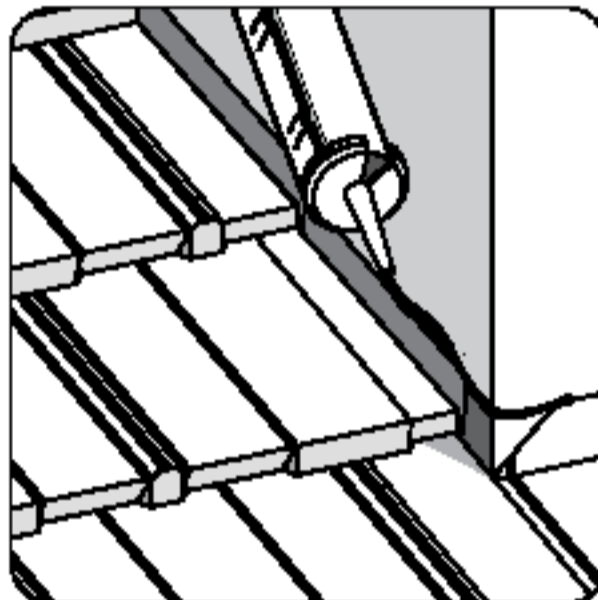

Seal around perimeter of folded panels prior to fastening them to the protrusion.

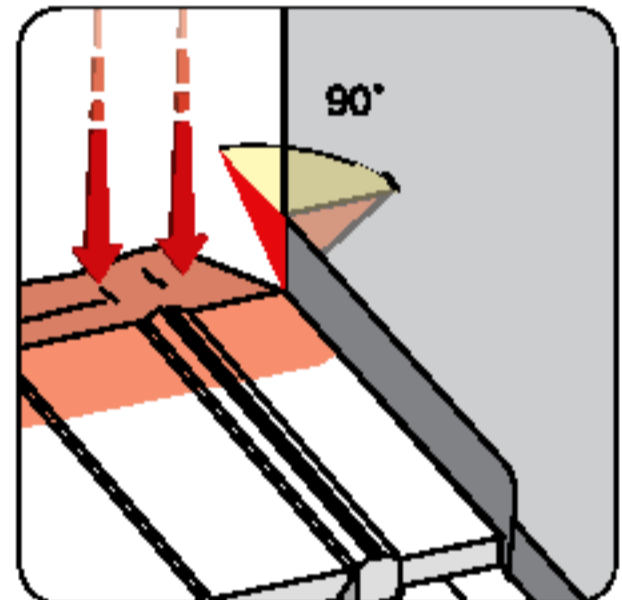

Flatten the back flange of the panel intersecting the top of the protrusion.

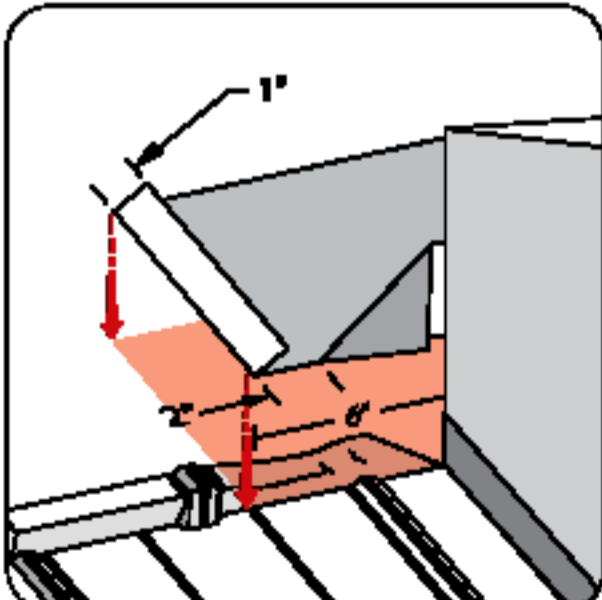

Install chimney saddle metal at back of chimney as shown. Extend Saddle metal a minimum of 4" past each side of protrusion.

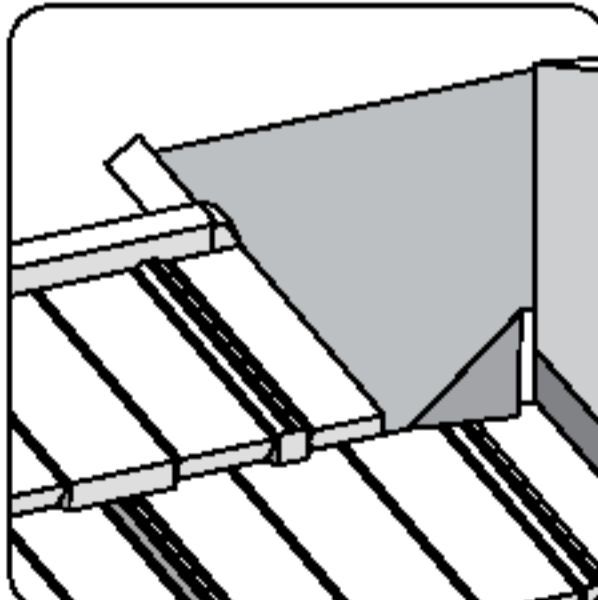

Install and seal 'Z'-bar flashing metal over folded sections as shown.

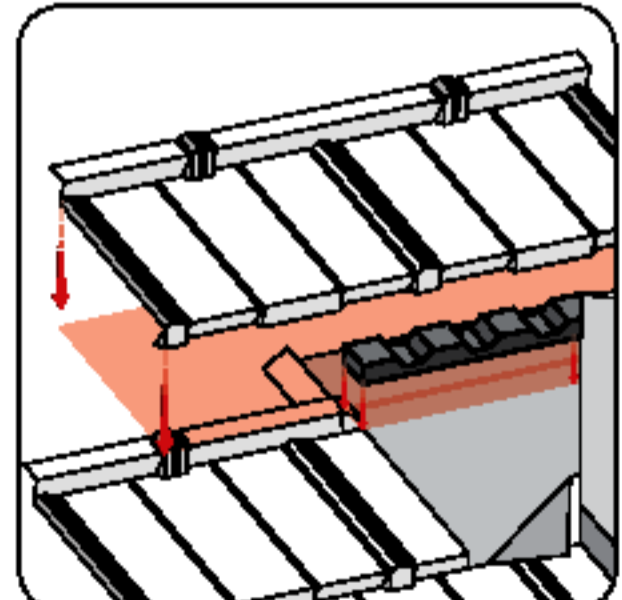

For added protection install a foam weather block as shown to seat the panel onto.

SIDE-WALL UNDER-PAN METAL

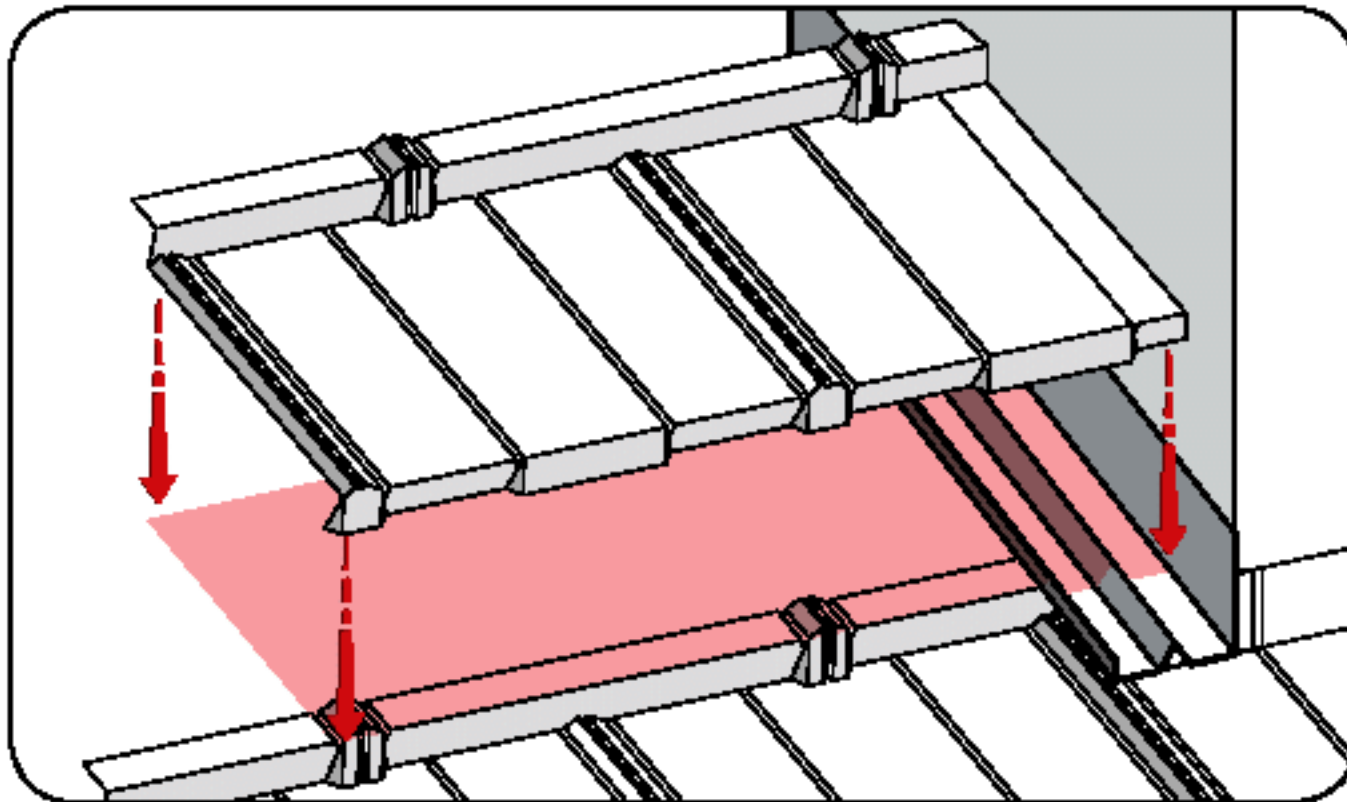

An alternate flashing method is to use side-wall Under-pan metal as shown. This can then be counter flashed using the Metro Counter Flashing metal or standard 'Z'-bar metal weatherproofed over the up stand of the side-wall under-pan metal.



Fold up nose of panel where under-pan metal exits on top of field panels below.

SHORT COURSE

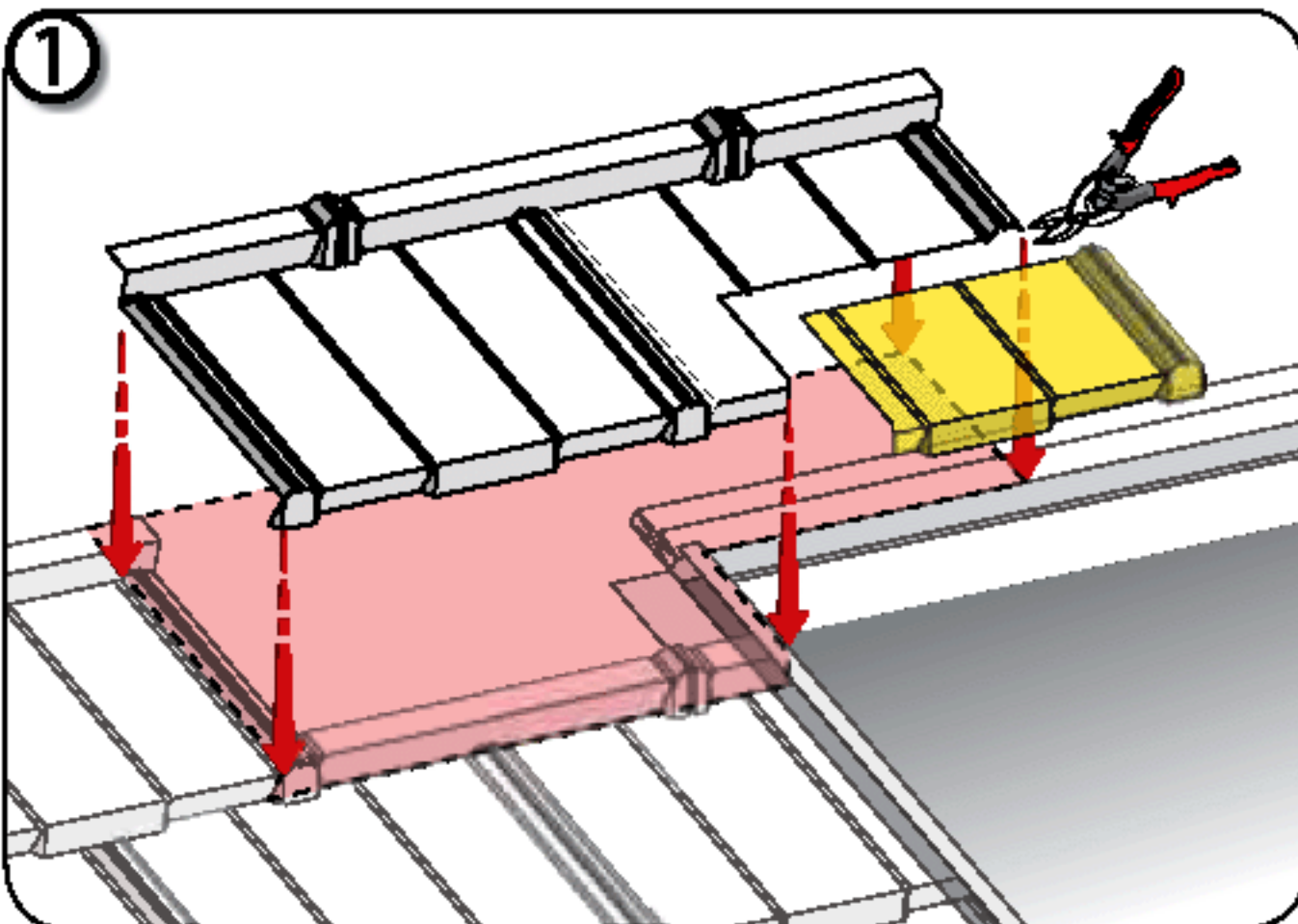

1 Cut the overhanging portion of the panel where it intersects with the stepped fascia as shown.

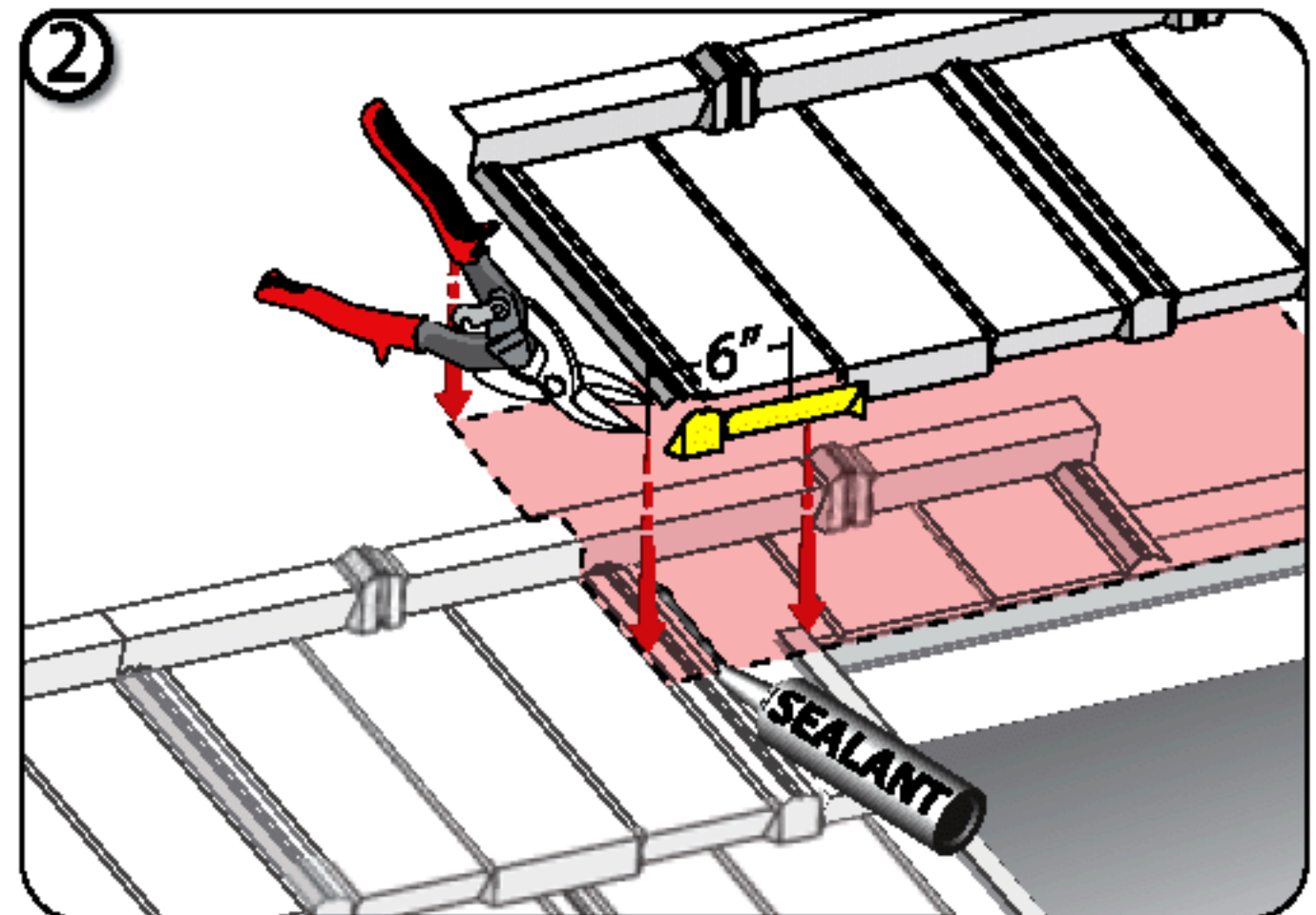

2 Lap over the first cut-panel with a new full panel and cut & remove the section as shown.

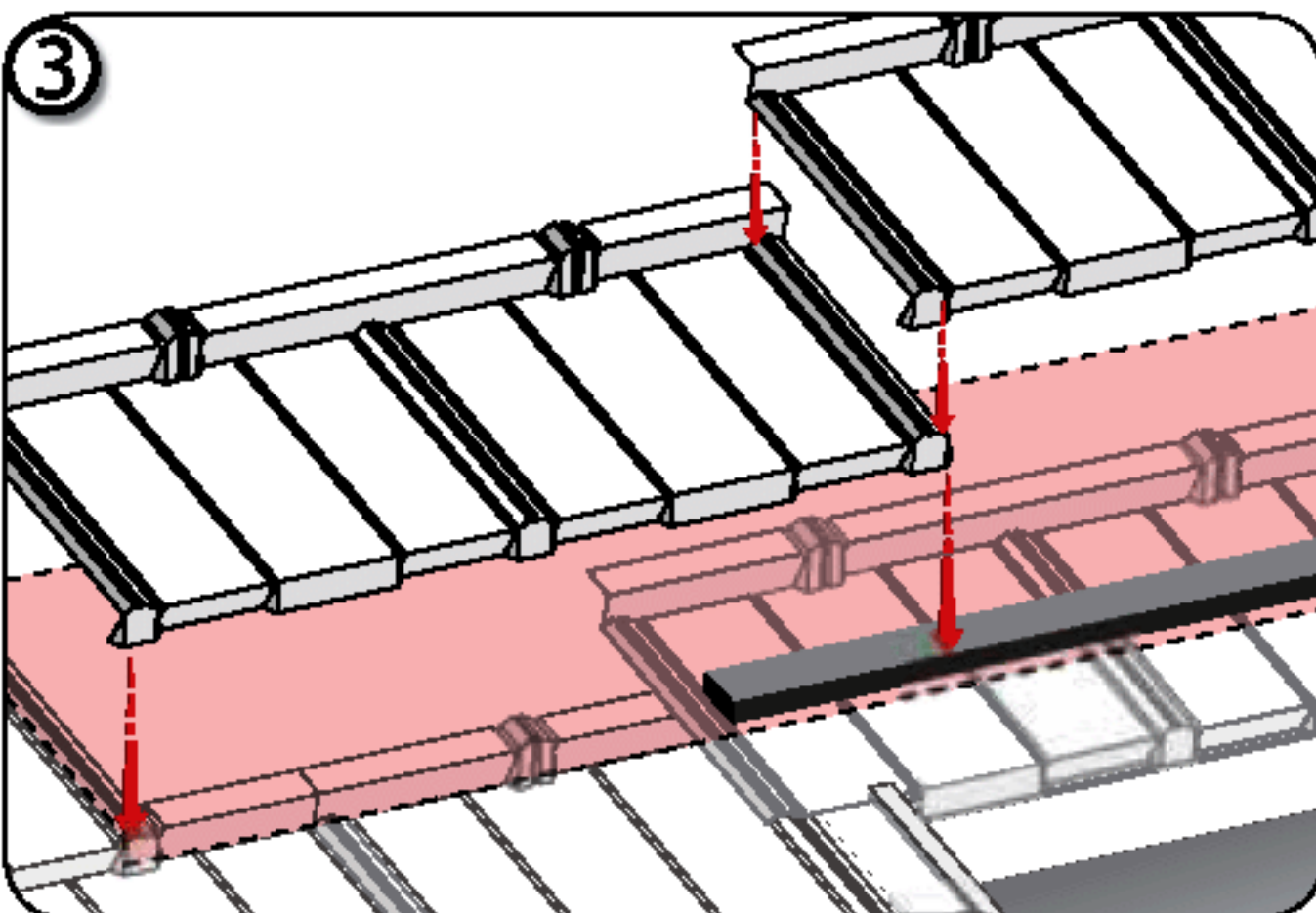

3 Apply either a bead of sealant or a strip of foam closure along the top surface of the lower panel, just behind the dotted line where the nose of the top panel will sit.

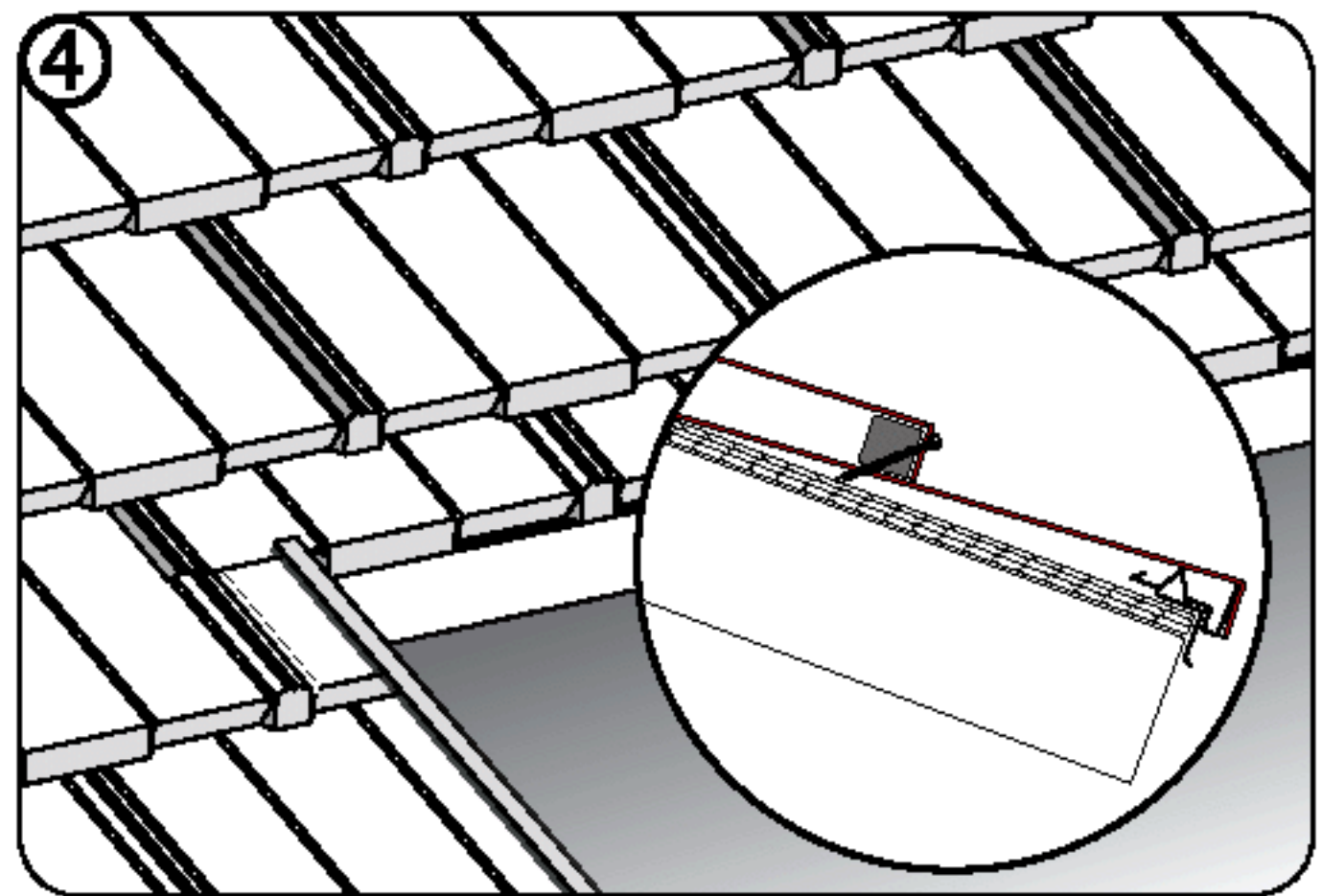

4 Finished slip-course detail with all parts in place



TRIM CAPS

HIP/RIDGE INTERSECTION
 Install hip caps from the bottom using 2 fasteners per trim cap. Overlap trim-caps at hip/ridge intersection. Cut and fit the ridge cap over both intersecting hip caps as shown.

RIDGE CENTER CAP
 At the center of a ridge line, a small/short ridge cap as shown can be made where cap pieces arrive from different directions.

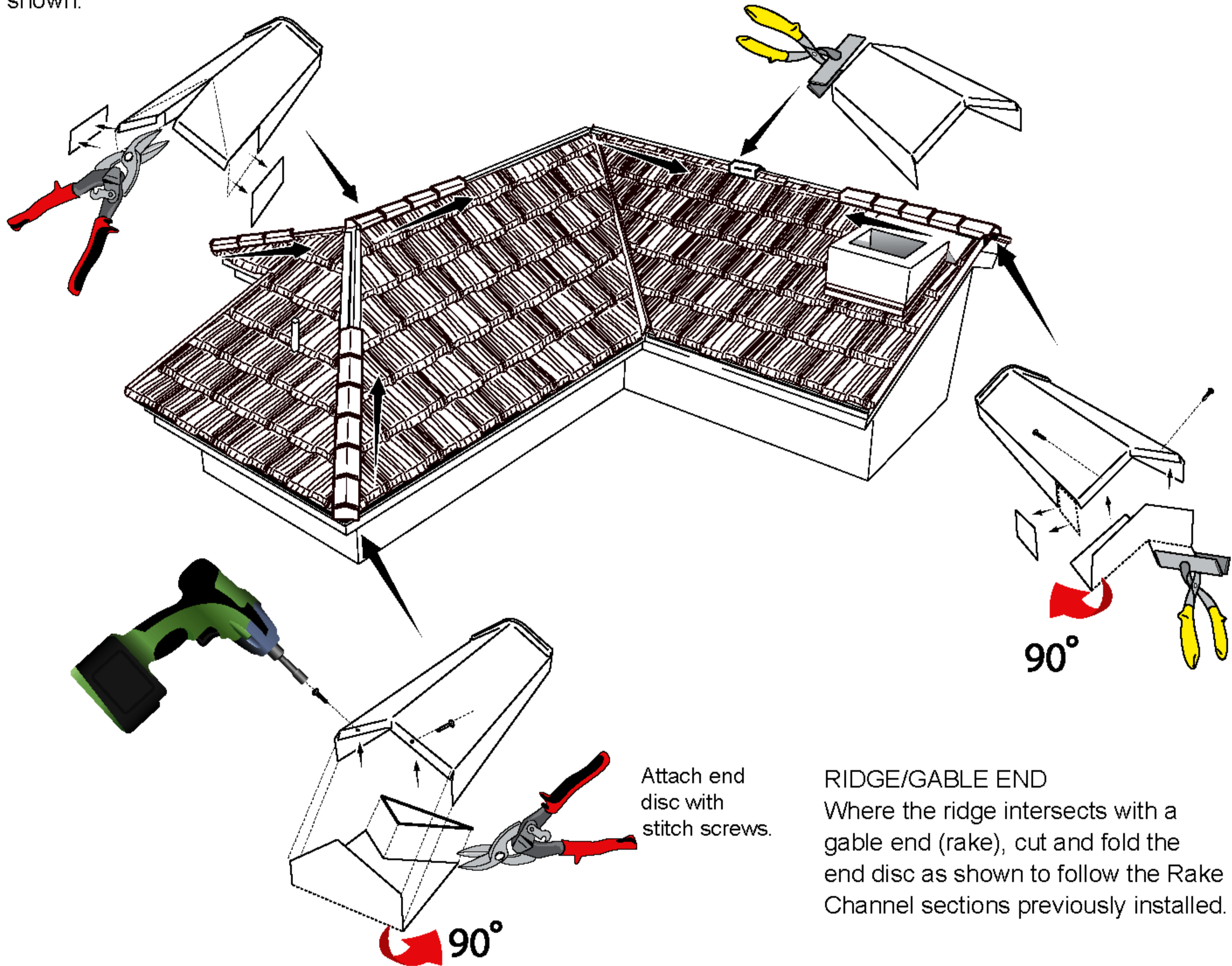

HIP CORNER
 Notch & fold the end disc as shown to form a closed 3-dimensional end cap. Fit end disc to bottom hip corner with stitch screws and install balance of trim caps up the hip. Nail each cap on either side of hip boards.

After installing trim-caps at intersections, seal cut edges and apply Metro basecoat and stone chip to provide a complete stone coat finish.